

电子电路与系统基础

习题课第十一讲

- 1、第八周作业讲解
- 2、第九周作业讲解
- 3、单管放大器实验电路说明

李国林
清华大学电子工程系

习题课第十一讲 大纲

- 第八周作业讲解
- 第九周作业讲解
- 单管放大器实验电路说明

第8周作业

作业3：二极管开关

- 如图所示为二极管开关控制信号传输电路，这里假设电容对直流信号是开路的，对交流小信号是短路的，分别求出控制电压 V_C 为 $0V$ 和 $5V$ 时的输出电压 v_L 波形

— 分别画出直流等效电路和交流等效电路

- 二极管直流模型：正偏 $0.7V$ 电压源，反偏开路
- 二极管交流模型：正偏短路，反偏开路

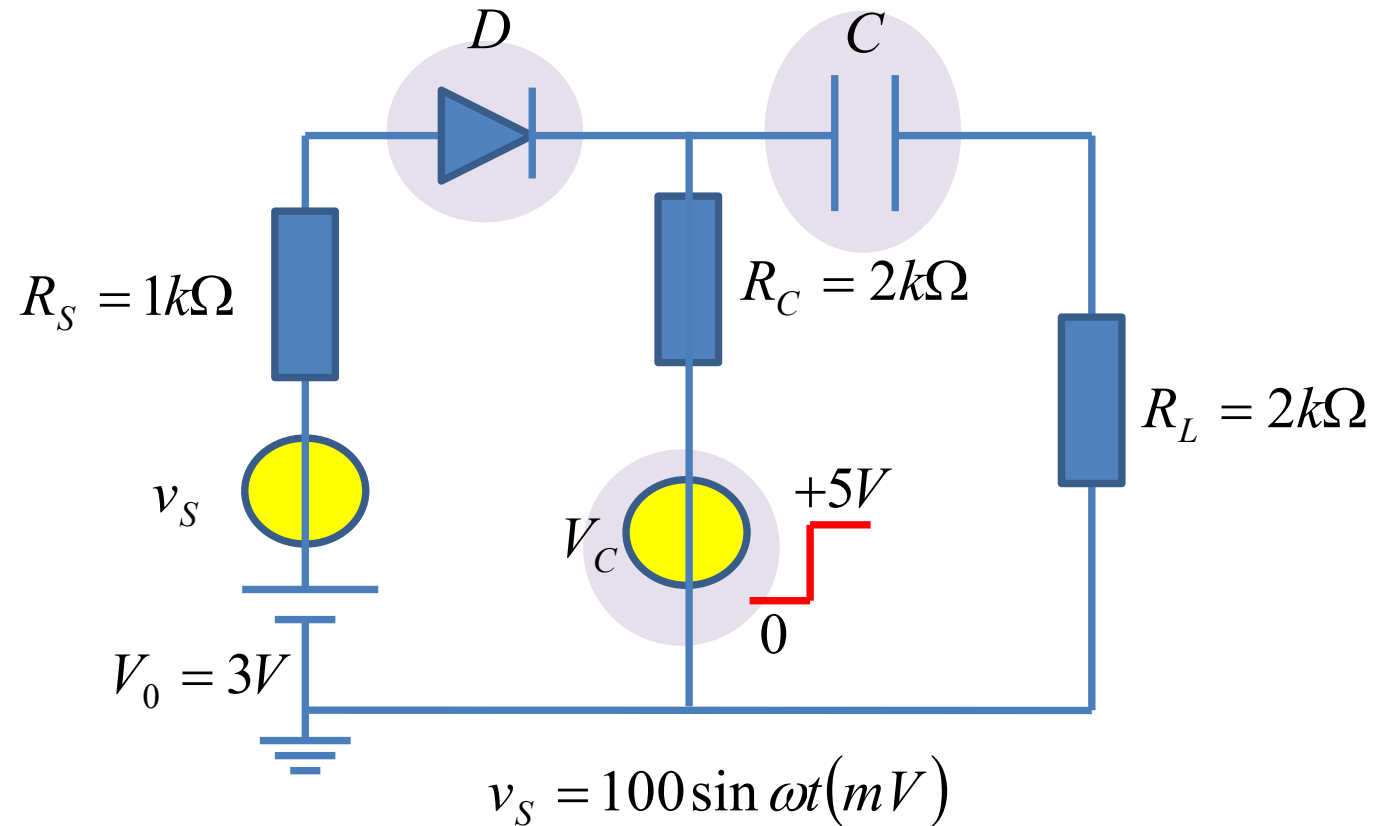

叠加定理不适用于非线性电路，直流分析是非线性分析
交流小信号在直流基础上起作用，是线性分析

二极管分段线性

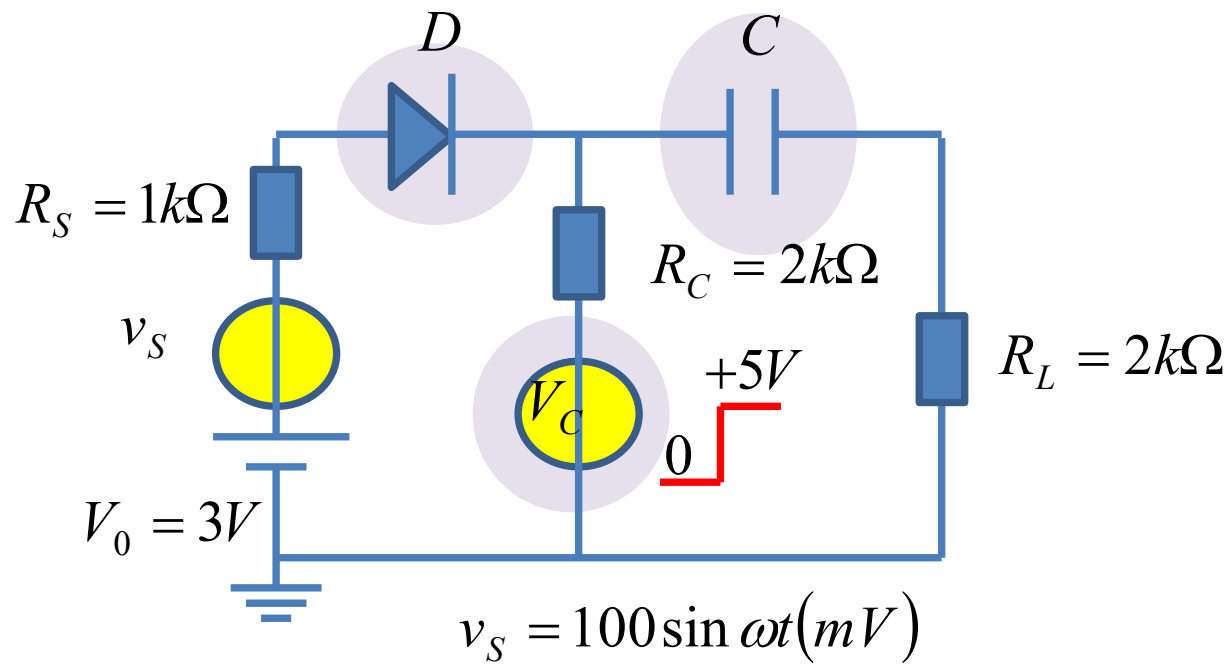

首要判定其工作区

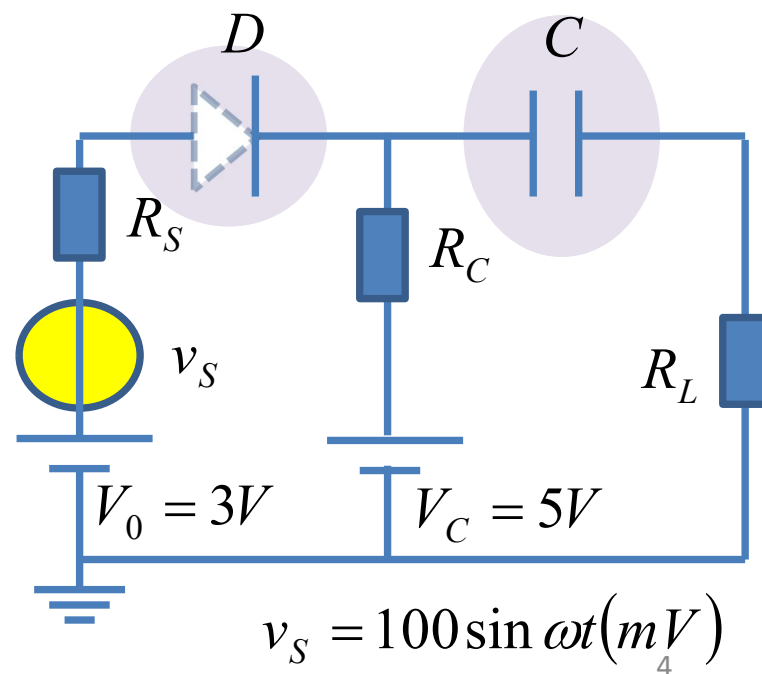
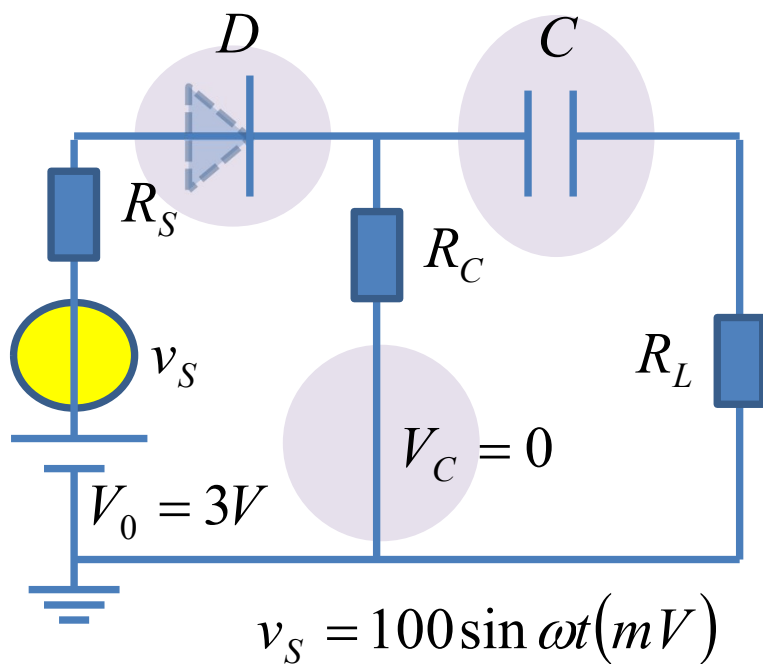

控制电压使导通

二极管导通，
直接采用**0.7V**
恒压源模型：
二极管直流电
流在**mA**量级，
微分电阻在
10Ω量级，和
负载电阻比可
认为短路

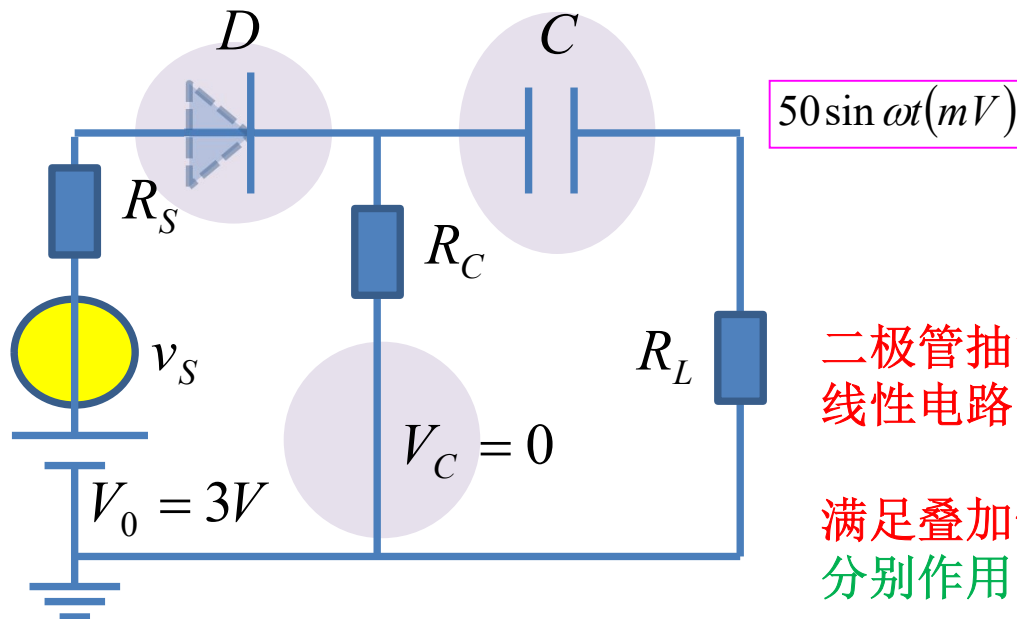

二极管抽象为恒压源
线性电路

满足叠加性
分别作用

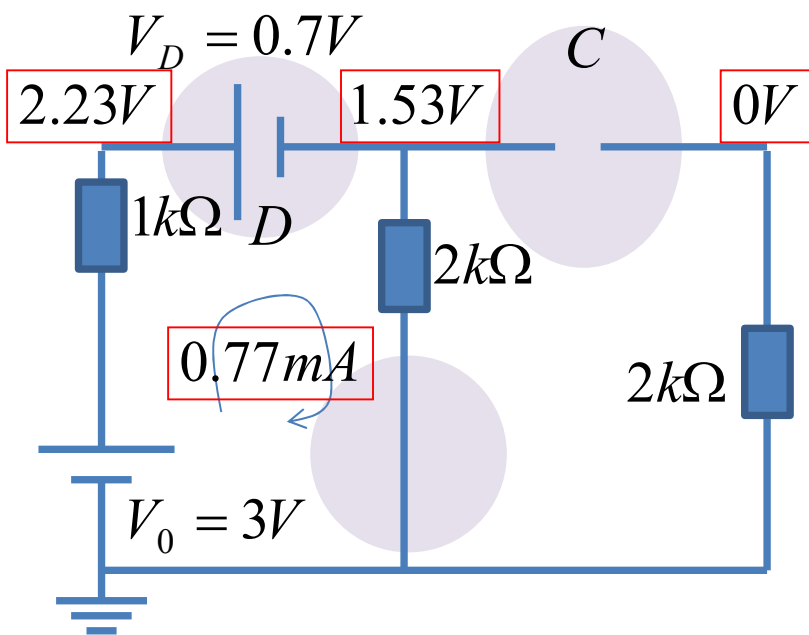

直流分析

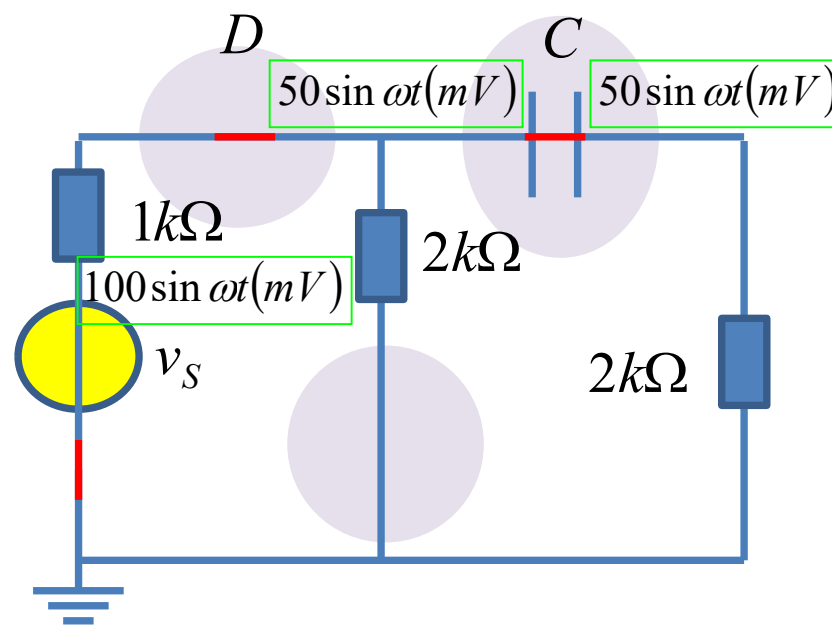

交流分析

控制电压使截止

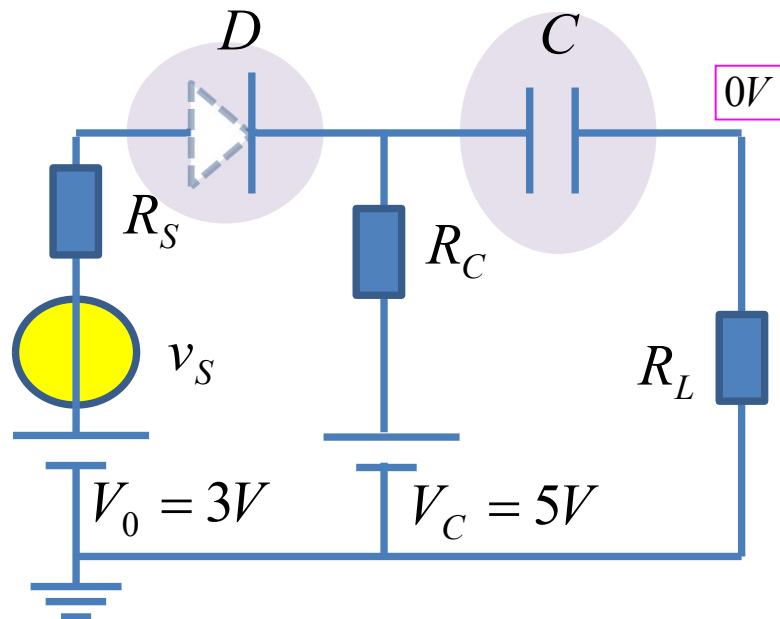

线性电路
满足叠加性

分别作用

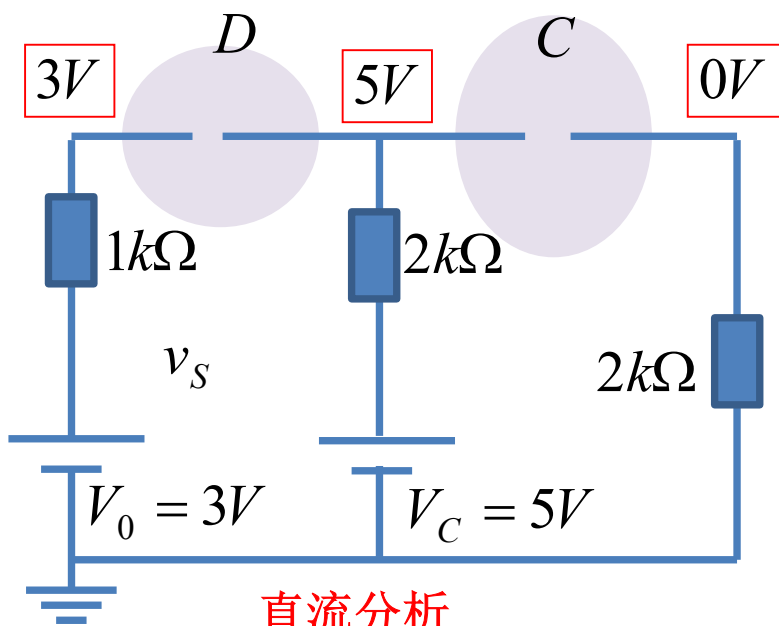

直流分析

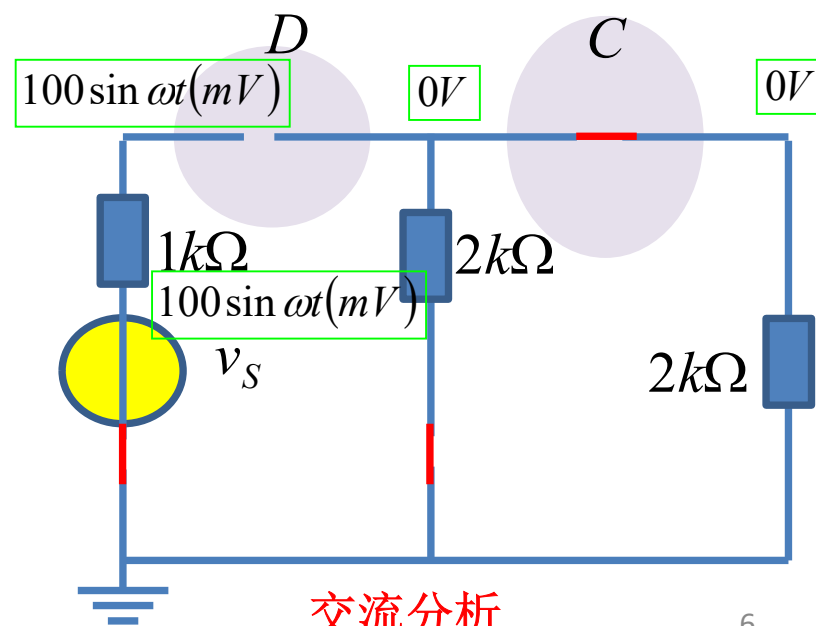

交流分析

输入输出波形

$$v_S = 100 \sin \omega t (mV)$$

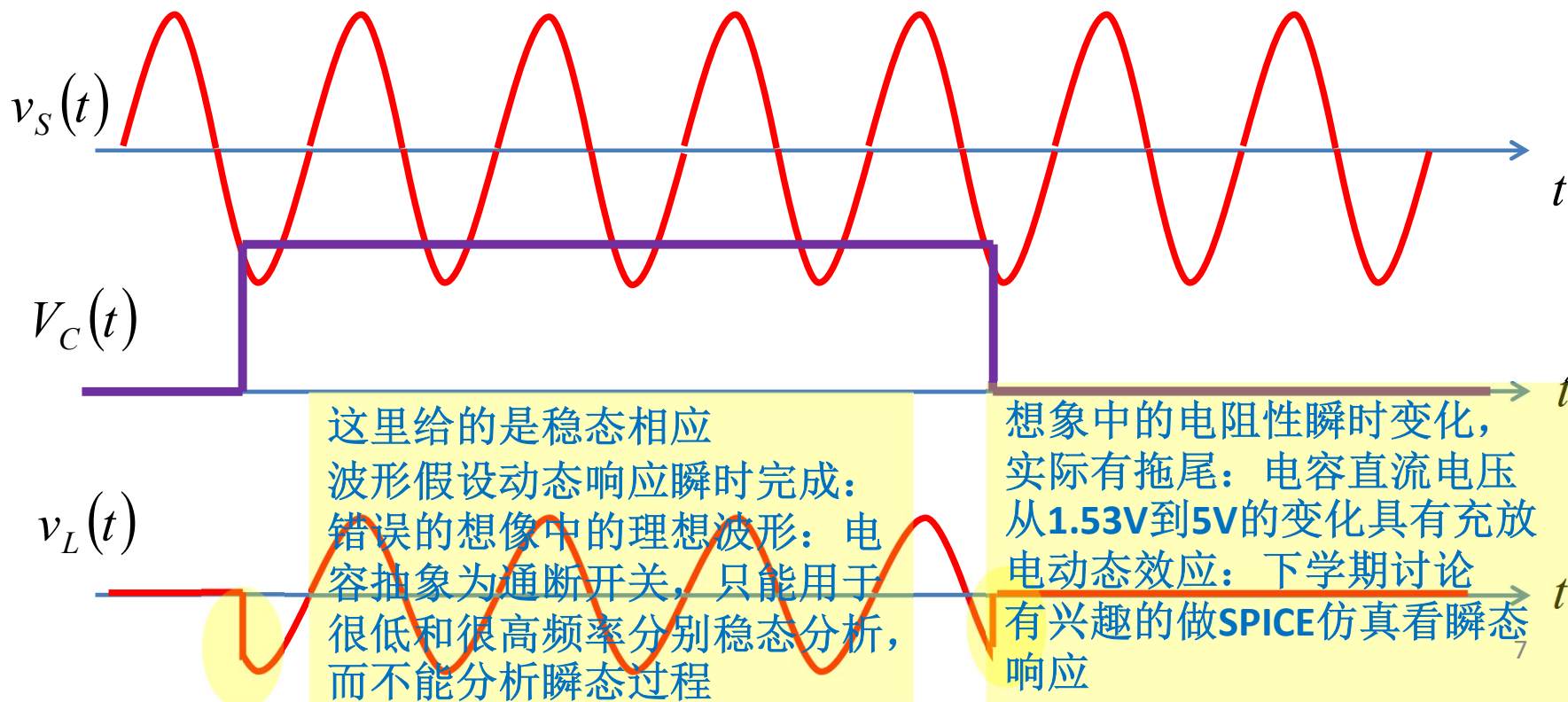
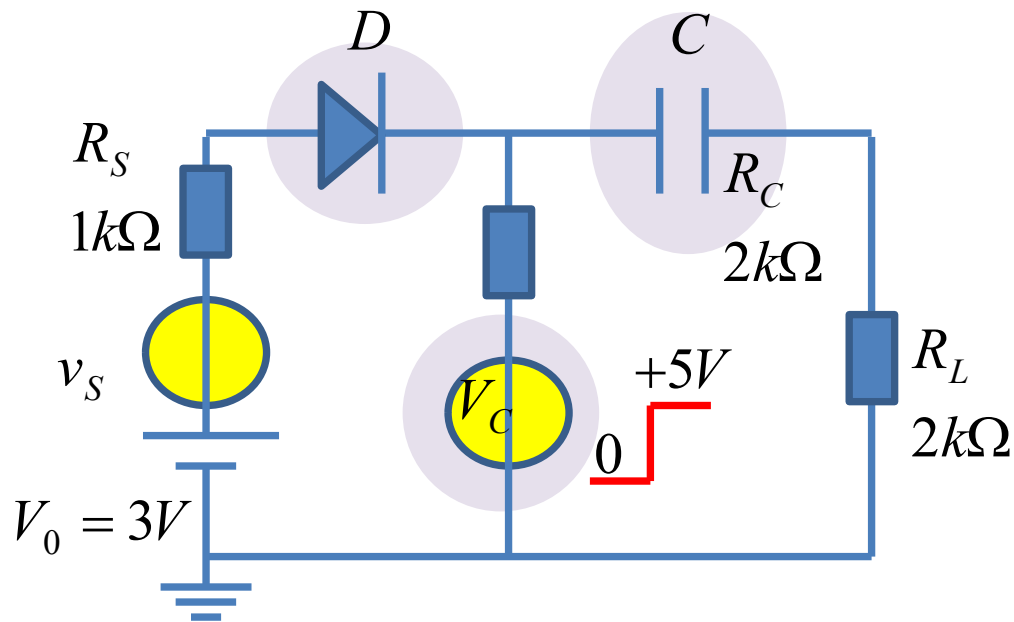

第8周作业

作业4：二极管数字门电路

- 我们将大于3V的电压视为逻辑状态1，将小于2V的电压视为逻辑状态0，2-3V的电压不定义其逻辑状态
 - (1) 给出如下两个电路的输出逻辑状态
 - (2) 用一句话说明逻辑与和逻辑或的逻辑运算规则（决策原则）
 - 其中逻辑1用‘同意’一词表述，逻辑0用‘不同意’一词表述
 - (3) 回答：联合国安理会‘一票否决制’采用的是与运算还是或运算？

V_1 (v)	V_2 (v)	V_3 (v)	D_1	D_2	D_3
0	0		0	0	
0	5		0	1	
5	0		1	0	
5	5		1	1	

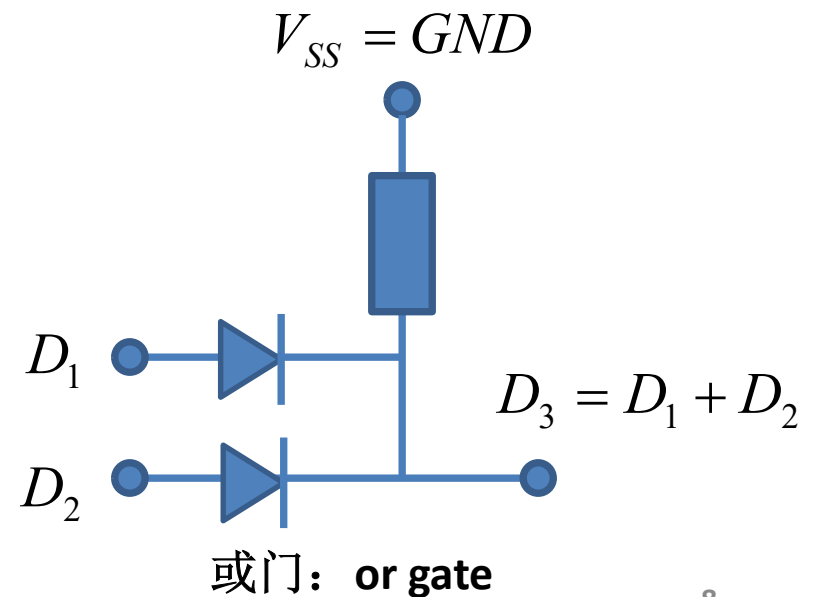
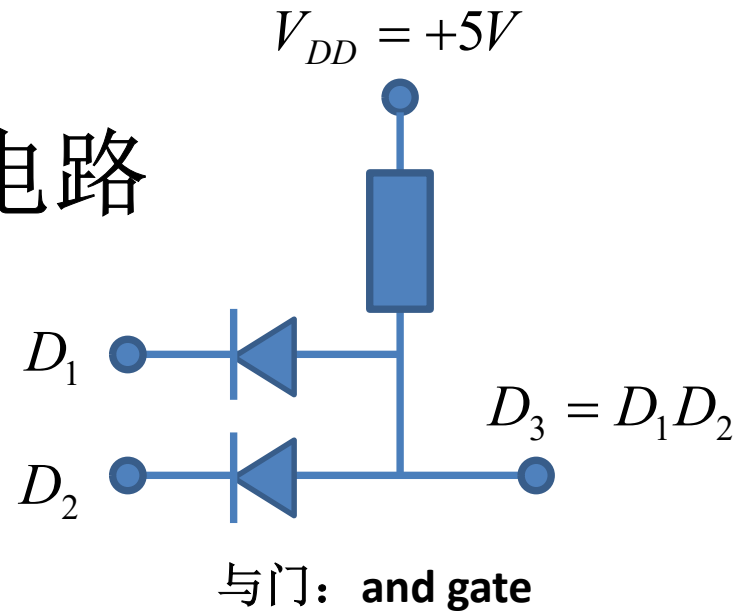

二极管：一阶模型

与门、或门逻辑

V_1 (v)	V_2 (v)	V_3 (v)	D_1	D_2	D_3
0	0	0.7	0	0	0
0	5	0.7	0	1	0
5	0	0.7	1	0	0
5	5	4.3	1	1	1

两个都同意方可通过

V_1 (v)	V_2 (v)	V_3 (v)	D_1	D_2	D_3
0	0	0	0	0	0
0	5	4.3	0	1	1
5	0	4.3	1	0	1
5	5	4.3	1	1	1

有一个同意即可通过

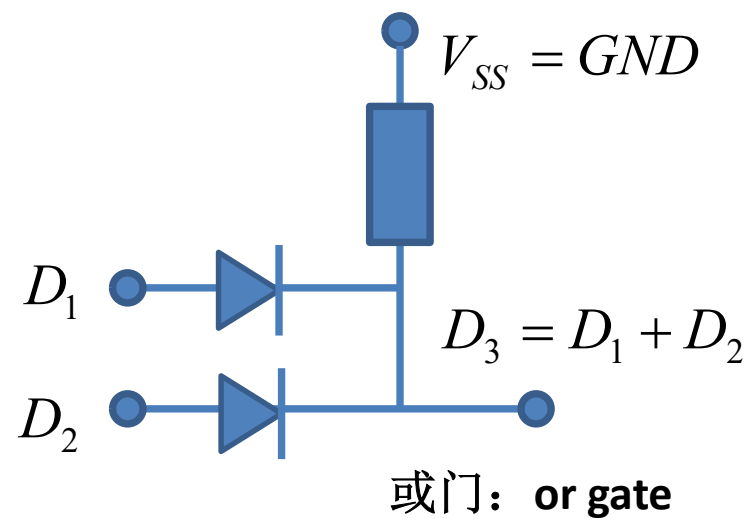
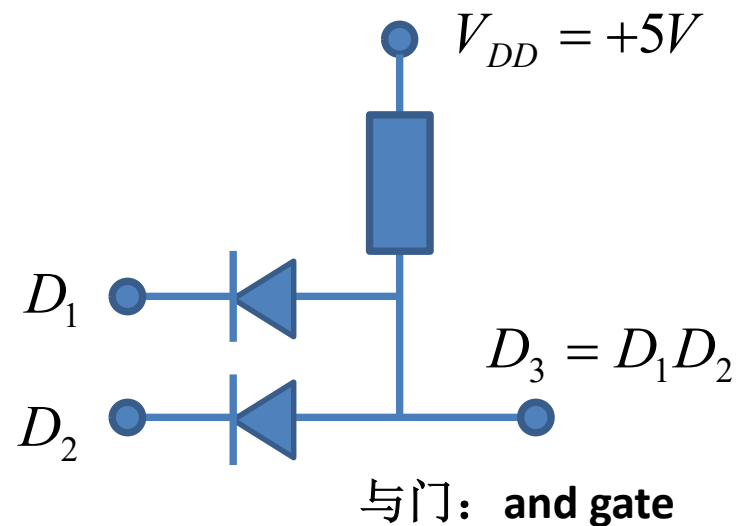

作业5 转移特性

作业中，普通PN结二极管均采用一阶模型：开关+0.7V偏压

- 画出如图所示电路的电压转移特性曲线

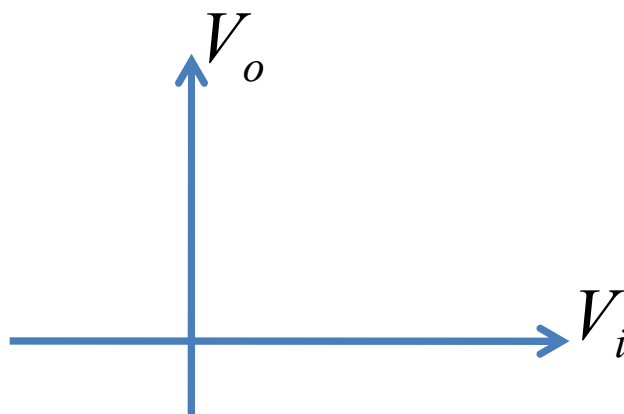
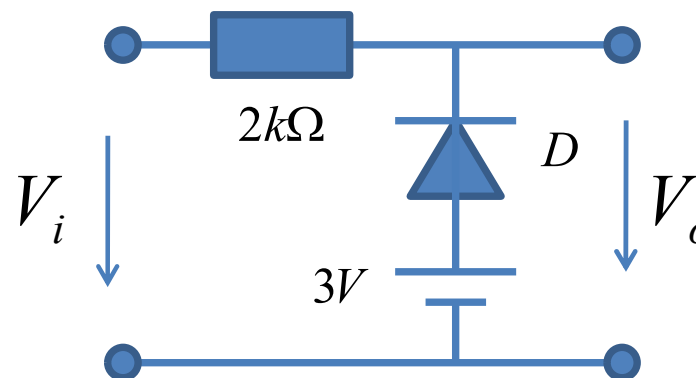
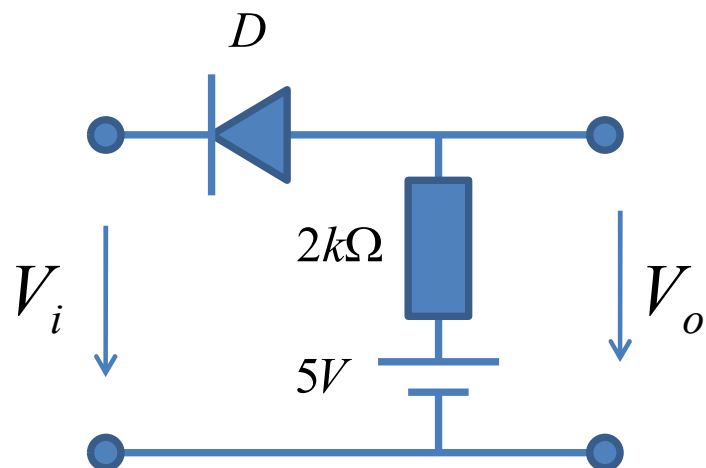

二极管模型

串接负载很小时，戴维南源内阻才会被考虑在内

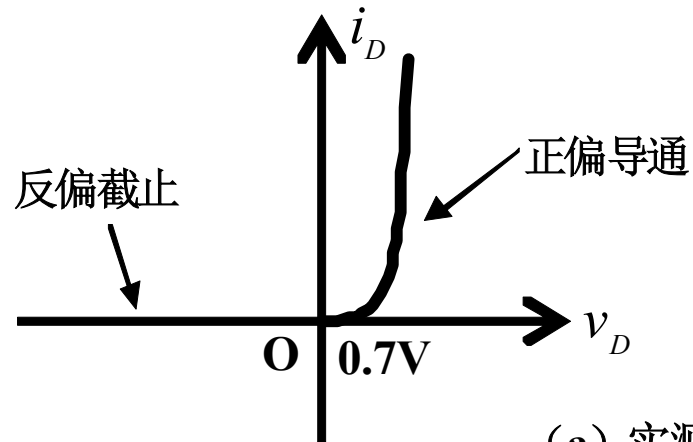

(a) 实测特性

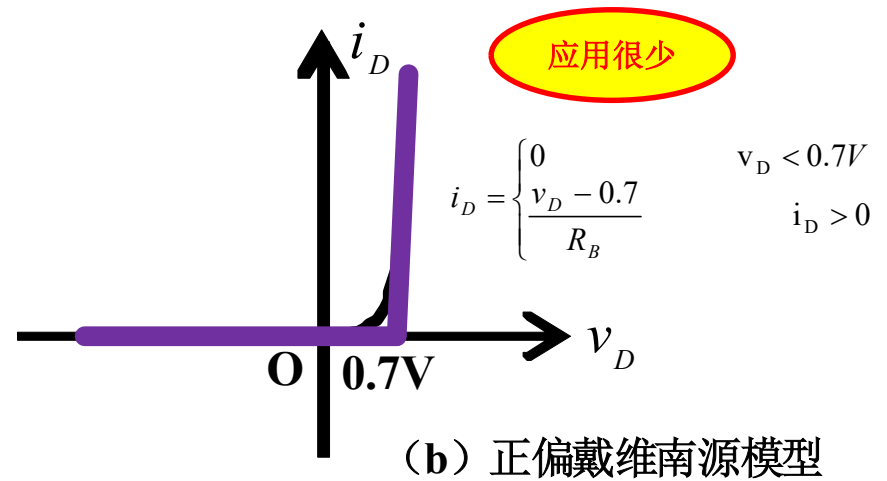

(b) 正偏戴维南源模型

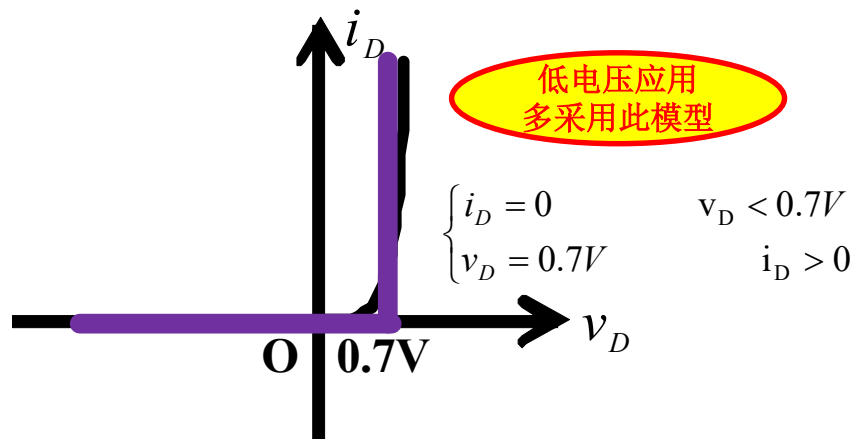

(c) 正偏恒压源模型

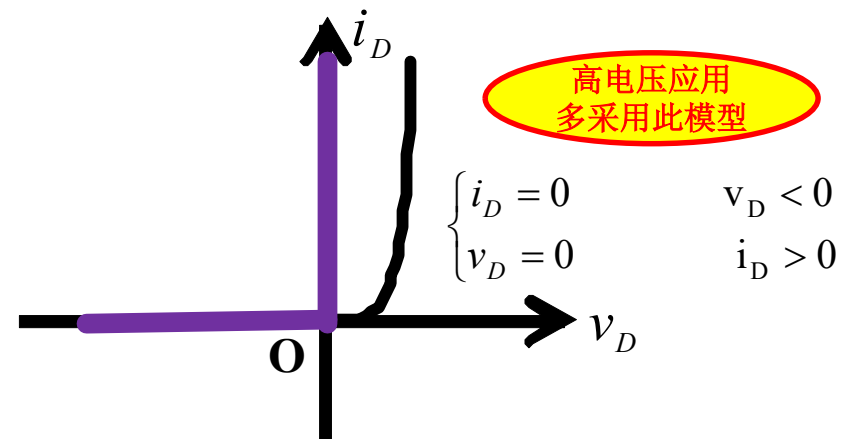

(d) 理想整流模型

二极管分段折线

正偏导通，反偏截止

- 分界判断

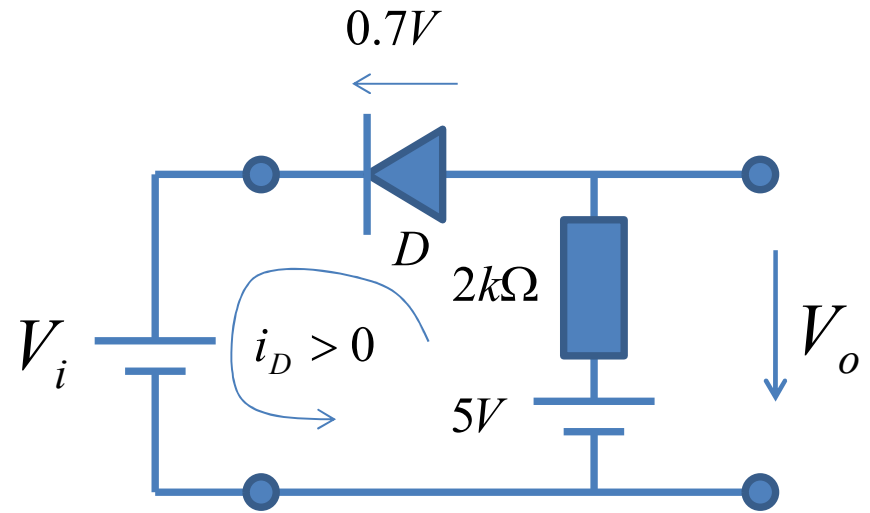
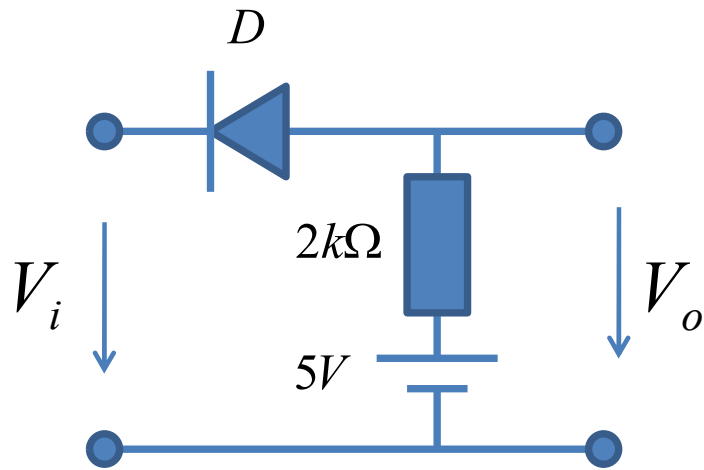

假设D正偏导通，则 $V_o = V_i + 0.7$

$$i_D = \frac{5 - 0.7 - V_i}{R} > 0$$

$$V_i < 4.3V$$

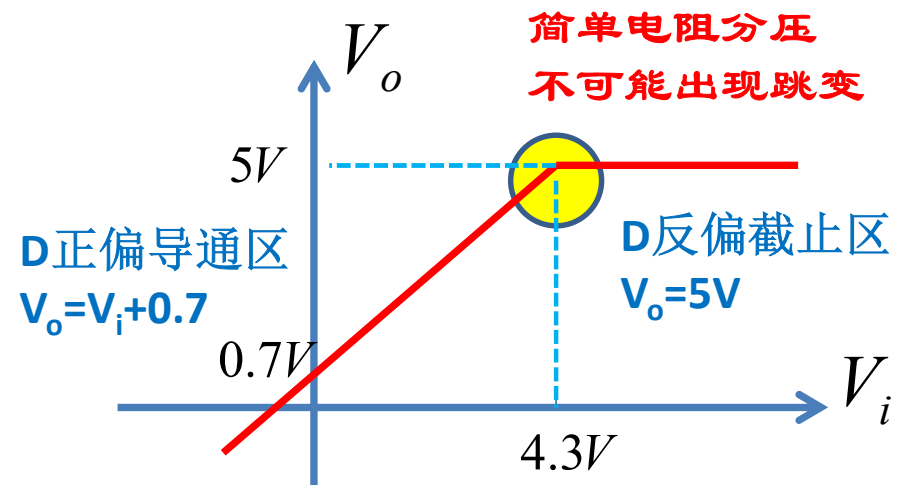

二极管分段折线

正偏导通，反偏截止

- 分界判断

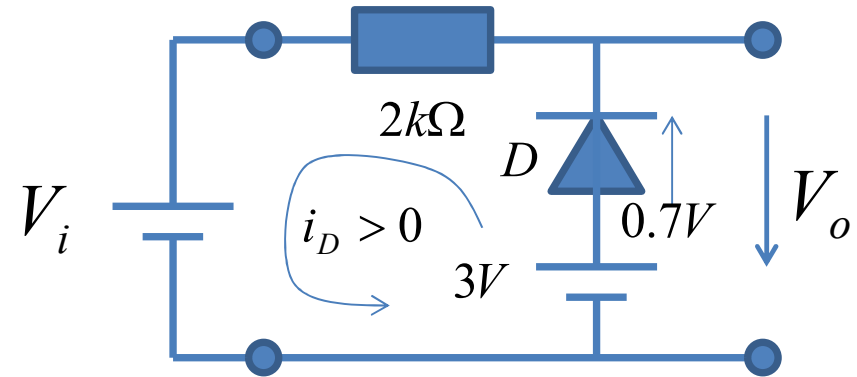

假设D正偏导通，则 $V_o=2.3V$

$$i_D = \frac{3 - 0.7 - V_i}{R} > 0 \quad V_i < 2.3V$$

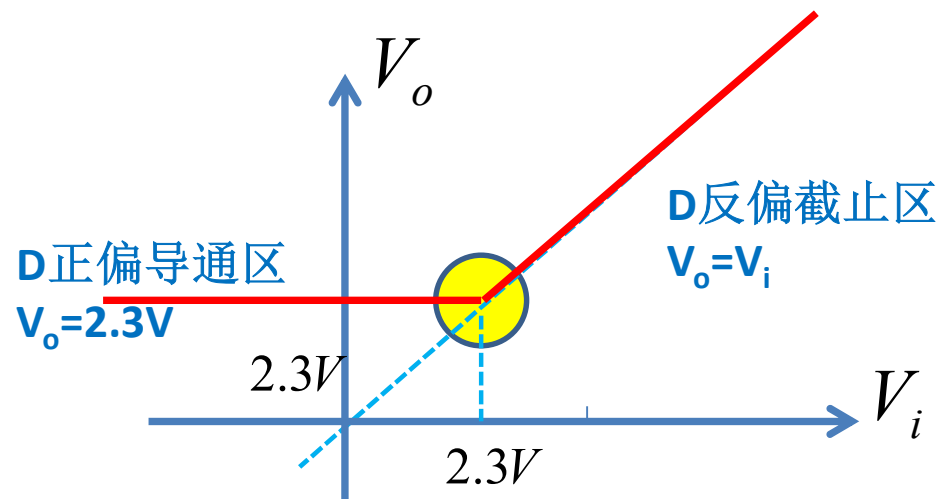
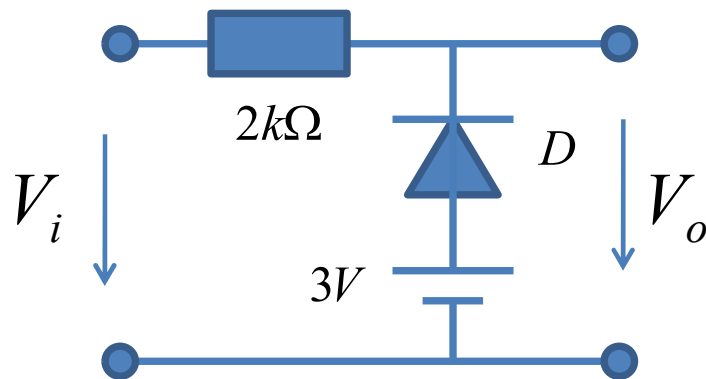

作业6 二极管稳压器

- 一个齐纳稳压电路，输入电压在**16V-20V**之间变动，齐纳二极管为**1N4733A**，负载电阻 R_L 要求负载电流为**6mA-20mA**才能正常工作，限流电阻 R_S 的取值范围是多少？
 - 齐纳二极管采用理想电压源模型，反向击穿假设为**5.1V**恒压
 - 当输入电压、限流电阻、负载电流都取中间值时，求所有元件上释放或消耗的功率大小

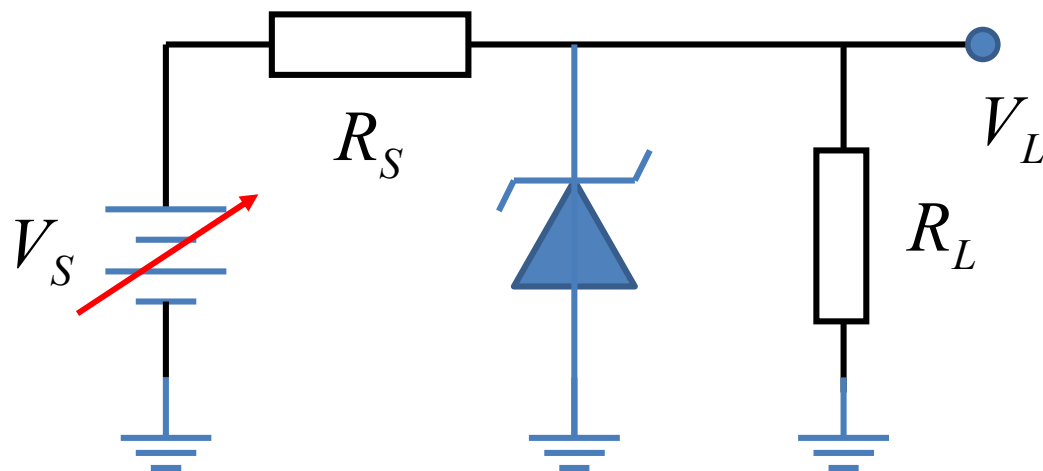

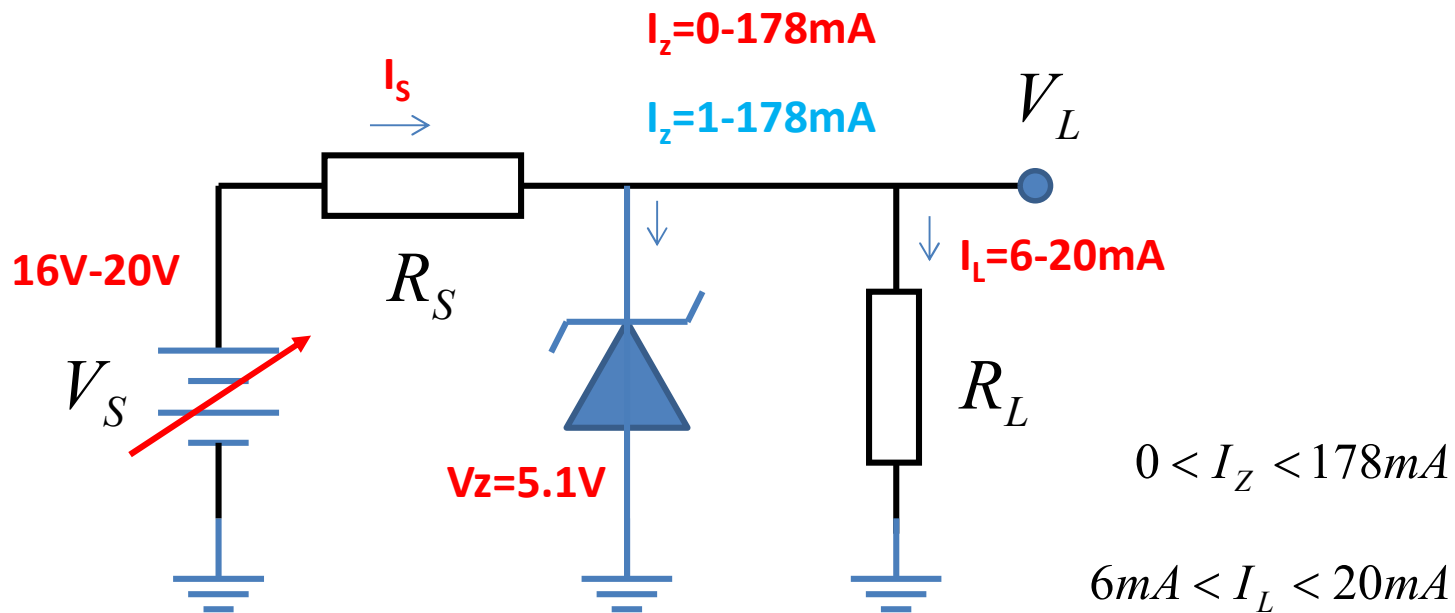

$$I_Z + I_L = I_S = \frac{V_S - V_Z}{R_S}$$

$$6 \sim 20mA = I_L < \frac{V_S - V_Z}{R_S} < 178 + I_L = 184 \sim 198mA$$

$$20mA < \frac{V_S - V_Z}{R_S} < 184mA$$

$$59 \sim 81\Omega = \frac{(16 \sim 20) - 5.1}{184mA} = \frac{V_S - V_Z}{184mA} < R_S < \frac{V_S - V_Z}{20mA} = \frac{(16 \sim 20) - 5.1}{20mA} = 545 \sim 745\Omega$$

功率分配情况

$$81\Omega < R_S < 545\Omega$$

$$81\Omega < R_S < 519\Omega$$

$R_S = 313\Omega$
结论差不多，自算

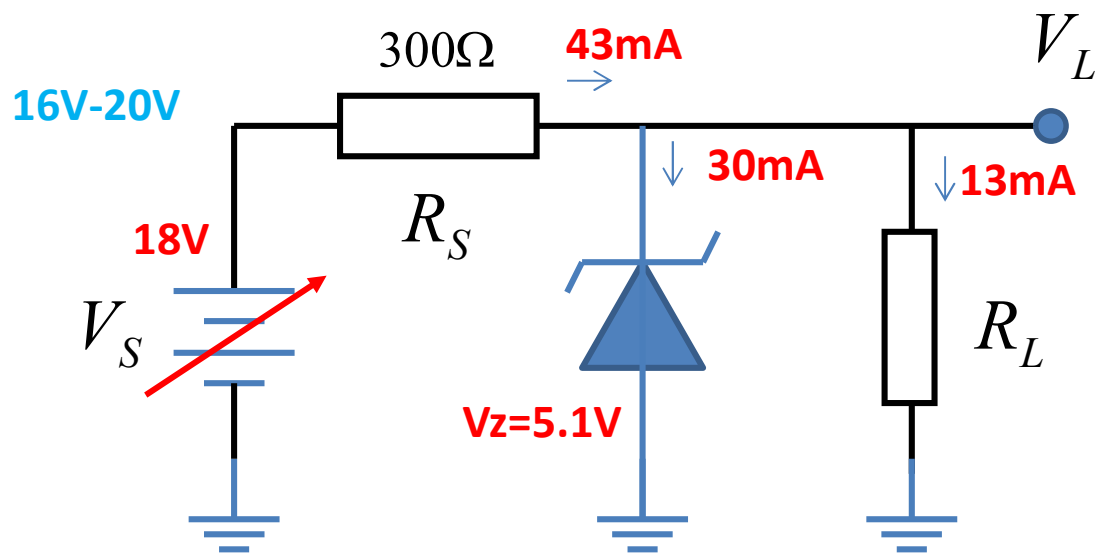

$$I_L = 6-20mA$$

$$P_{V_S} = P_{R_S} + P_D + P_L$$

(1) 能量守恒：电源之外都是阻性器件

$$\eta = \frac{P_L}{P_{V_S}} = \frac{66.3}{774} = 8.57\%$$

(2) 效率很低

(3) 负载端口向内部看，齐纳二极管提供的是恒压特性， V_S 则提供能量，整体等效为5.1V恒压源

$$I_S = \frac{V_S - V_Z}{R_S} = \frac{18 - 5.1}{300} = 0.043A = 43mA$$

$$I_R = I_S - I_L = 43 - 13 = 30mA$$

$$P_{V_S} = V_S I_S = 18V \times 43mA = 774mW \quad \text{源释放功率}$$

$$P_{R_S} = I_S^2 R_S = (43mA)^2 \times 300\Omega = 554.7mW \quad \text{限流电阻耗能}$$

$$P_D = V_Z I_Z = 5.1V \times 30mA = 153mW \quad \text{齐纳二极管耗能}$$

$$P_L = V_Z I_L = 5.1V \times 13mA = 66.3mW \quad \text{负载电阻耗能}$$

作业7 限幅器

- 分析说明图示电路为什么有这样的输出电压波形？

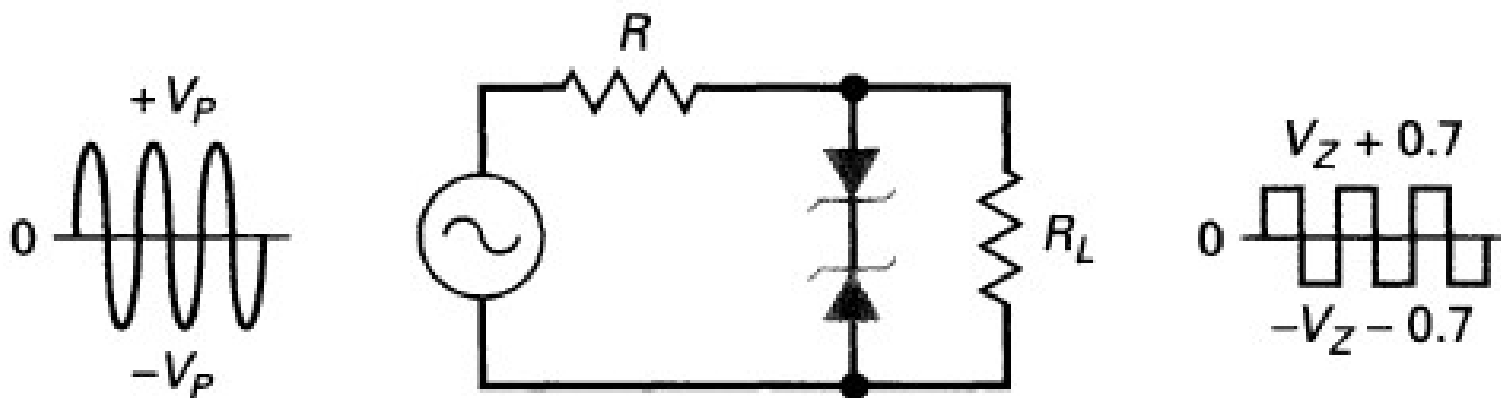

稳压二极管串联

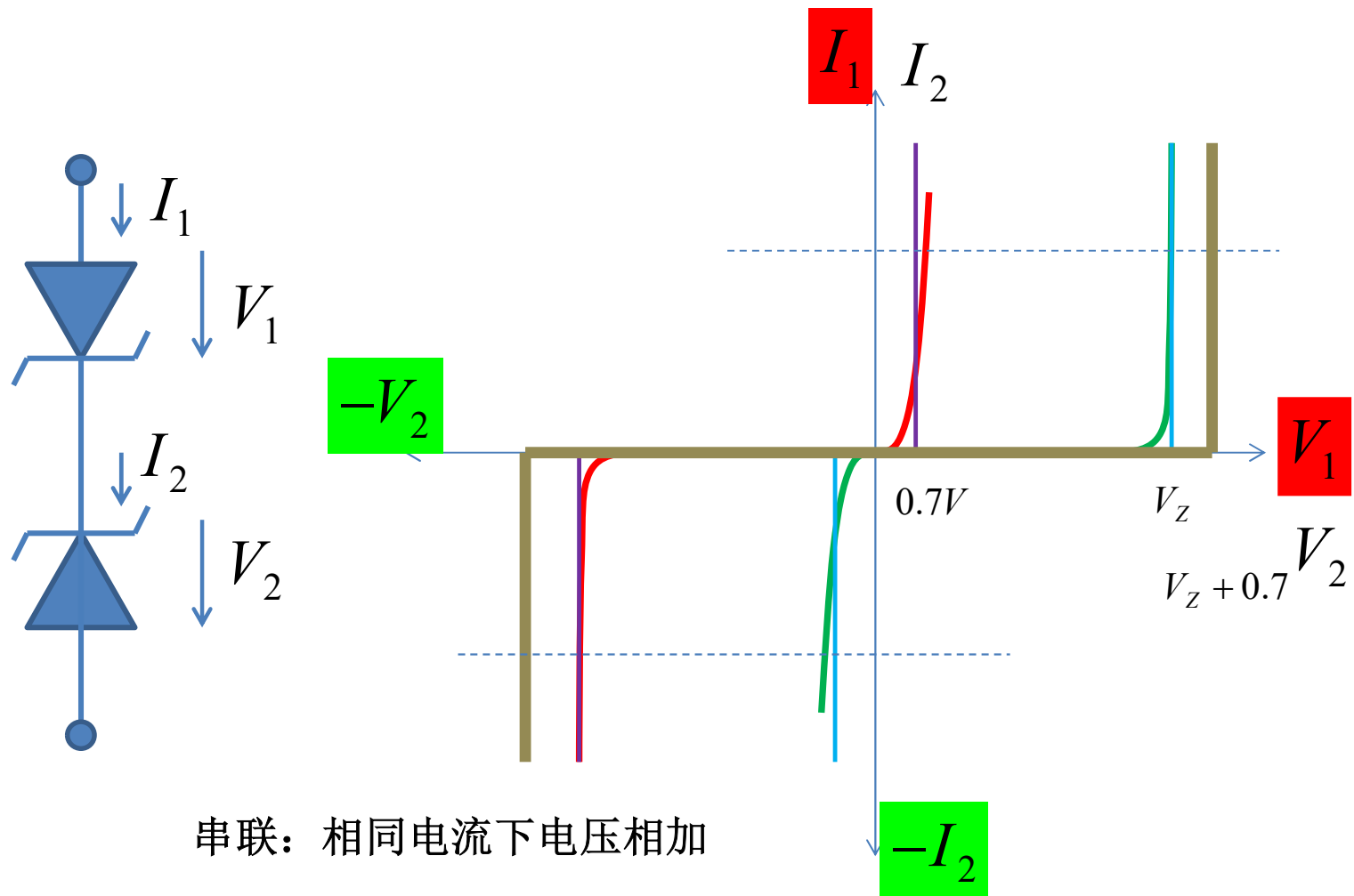
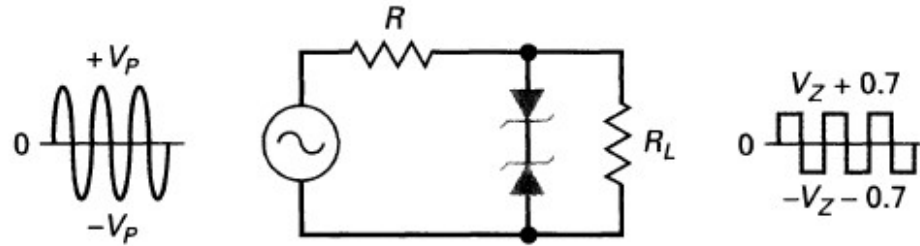

串联：相同电流下电压相加

分段折线电路模型

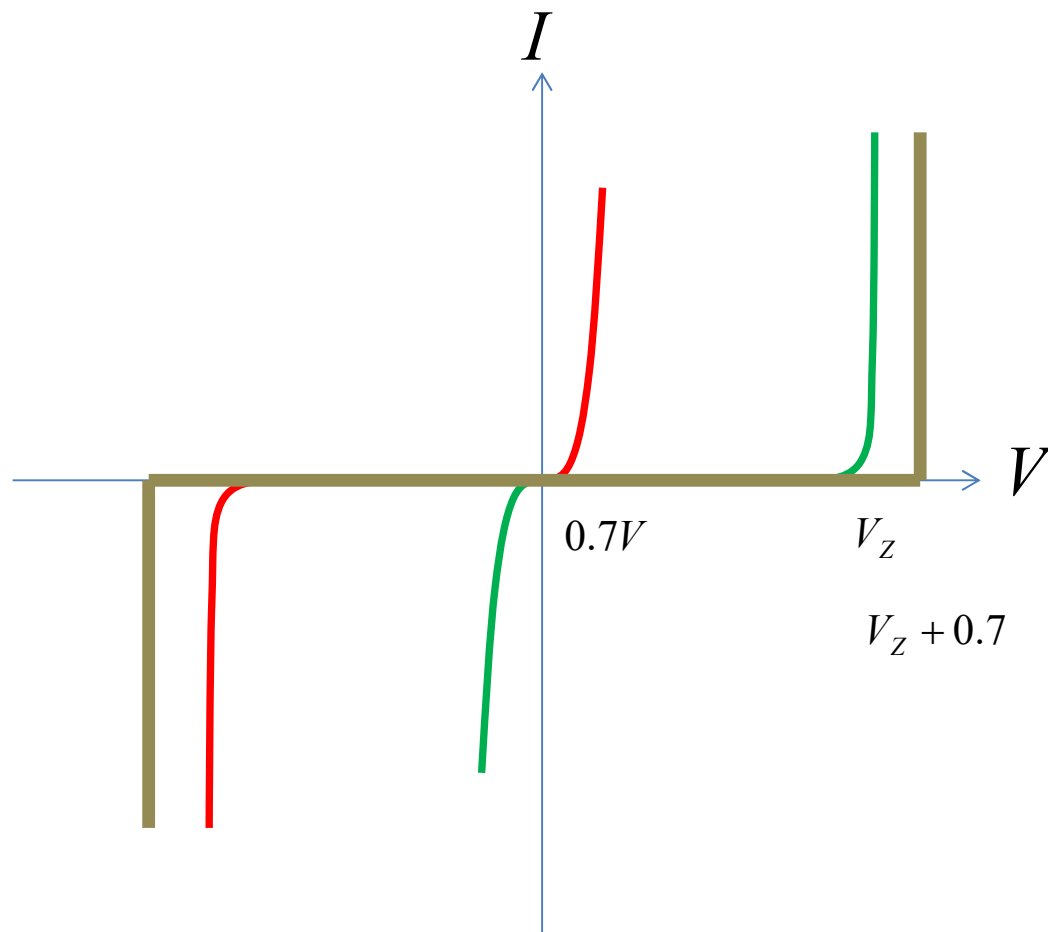
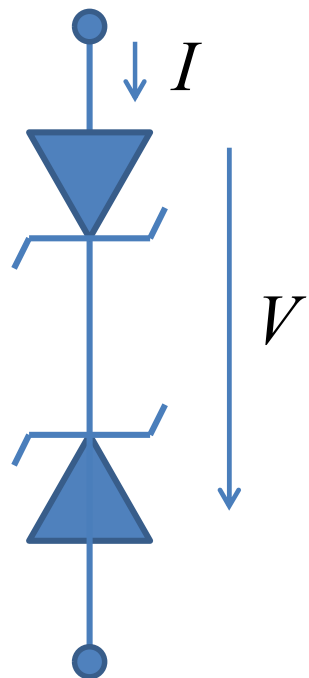

$$\begin{cases}
 V = +V_Z + 0.7 & I > 0 & \text{恒压源} \\
 I = 0 & -V_Z - 0.7 < V < +V_Z + 0.7 & \text{开路} \\
 V = -V_Z - 0.7 & I < 0 & \text{恒压源}
 \end{cases}$$

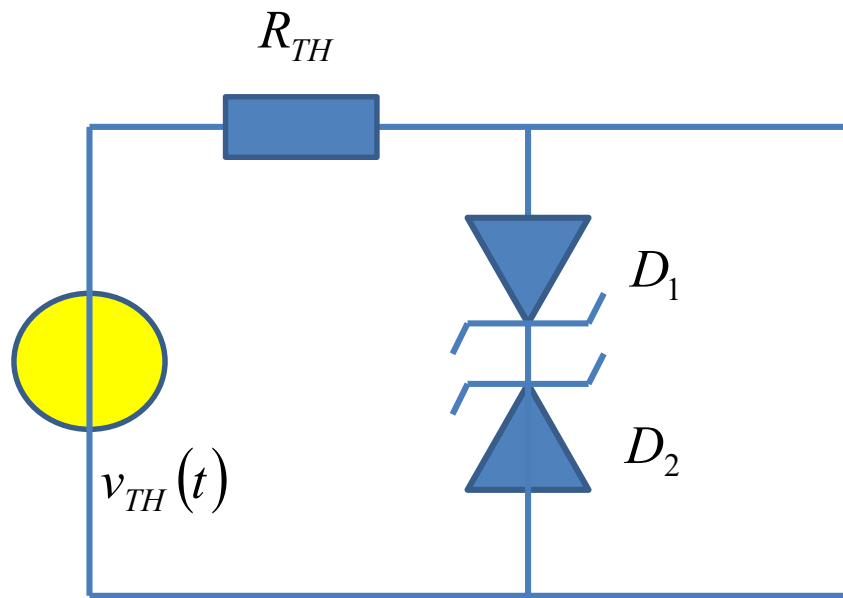
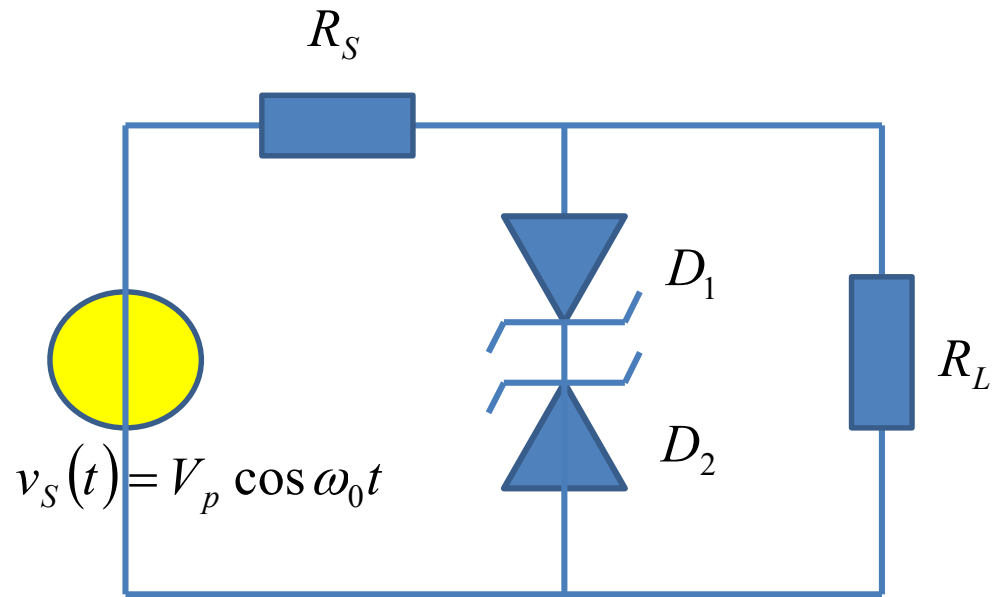

$$v_{TH}(t) = \frac{R_L}{R_L + R_S} v_S(t)$$

$$= \eta V_p \cos \omega_0 t$$

$$R_{TH} = \frac{R_L R_S}{R_L + R_S}$$

图解法理解

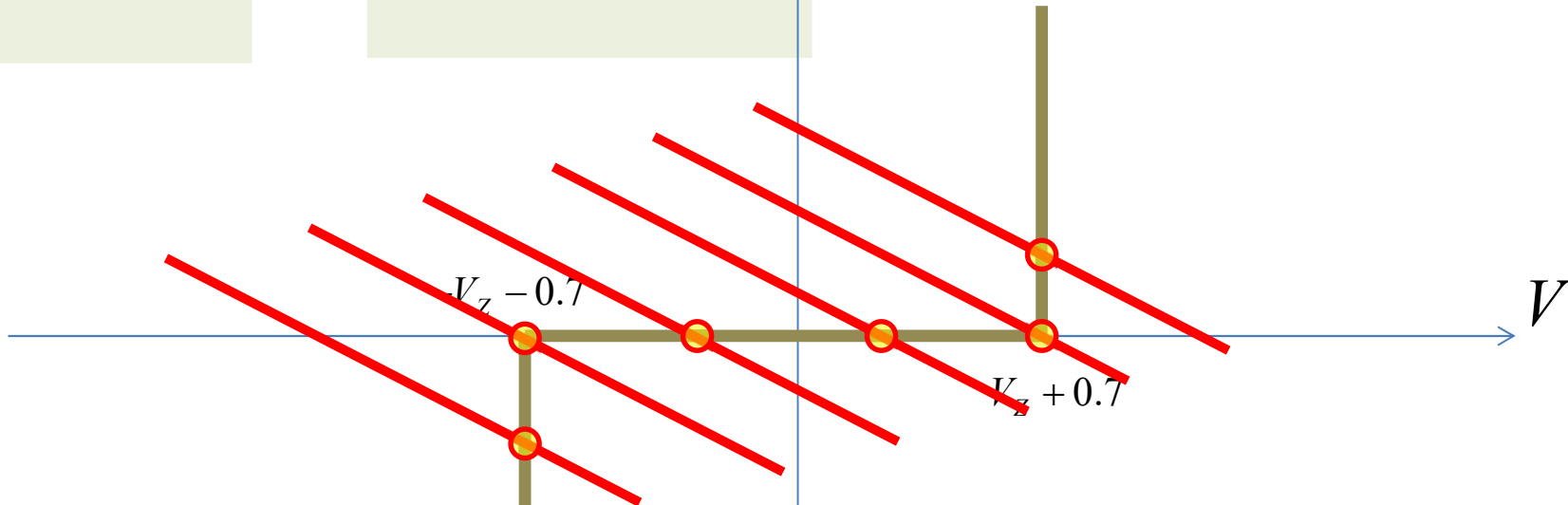
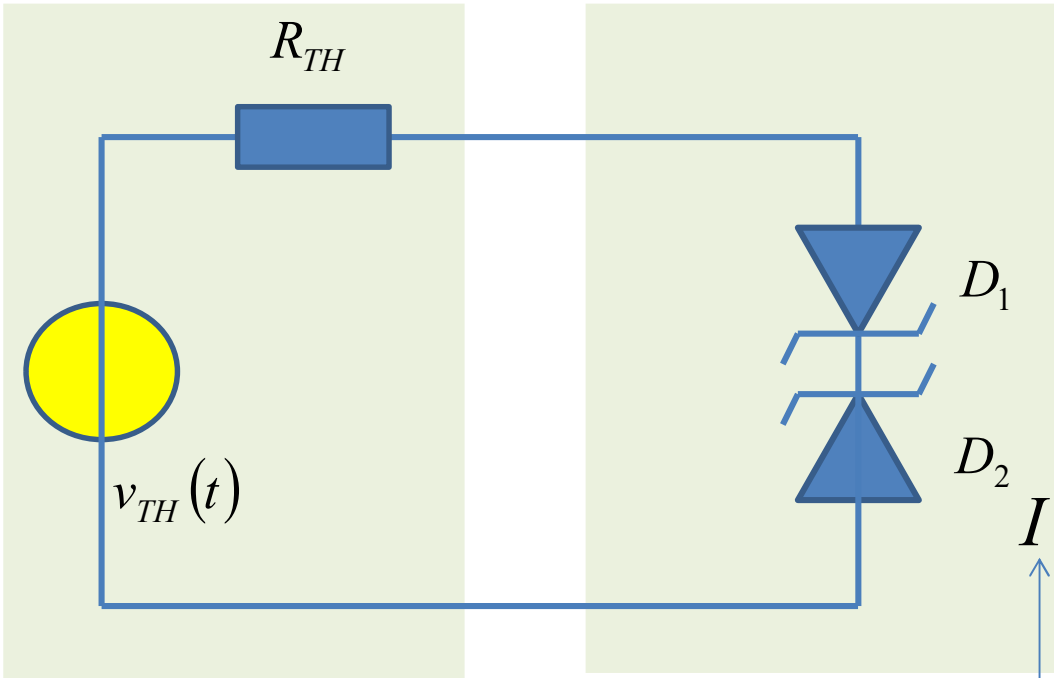

$-V_Z - 0.7 < v_{TH}(t) < +V_Z + 0.7$ 开路
 $v_{TH}(t) > +V_Z + 0.7$ $V_Z + 0.7$ 恒压源
 $v_{TH}(t) < -V_Z - 0.7$ $-V_Z - 0.7$ 恒压源

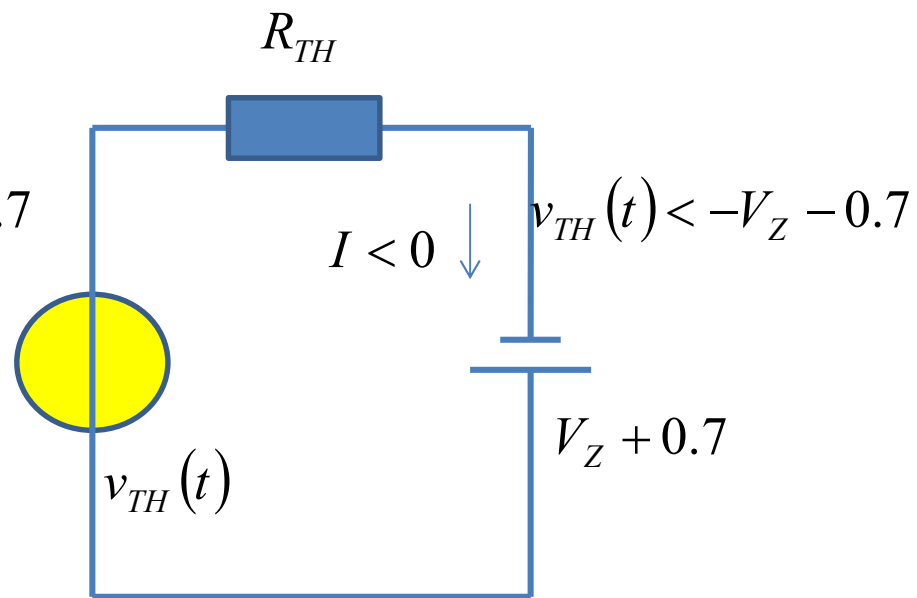
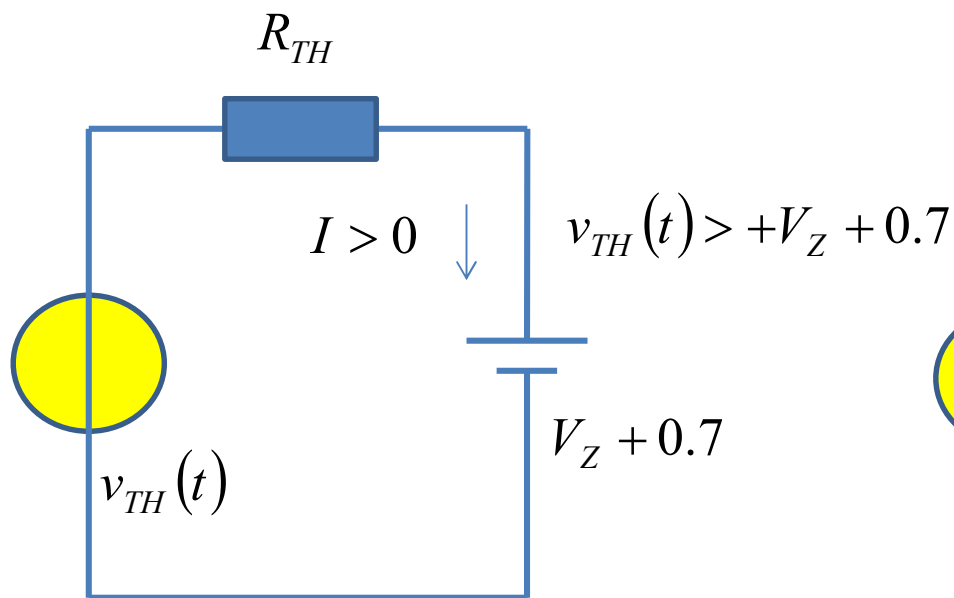
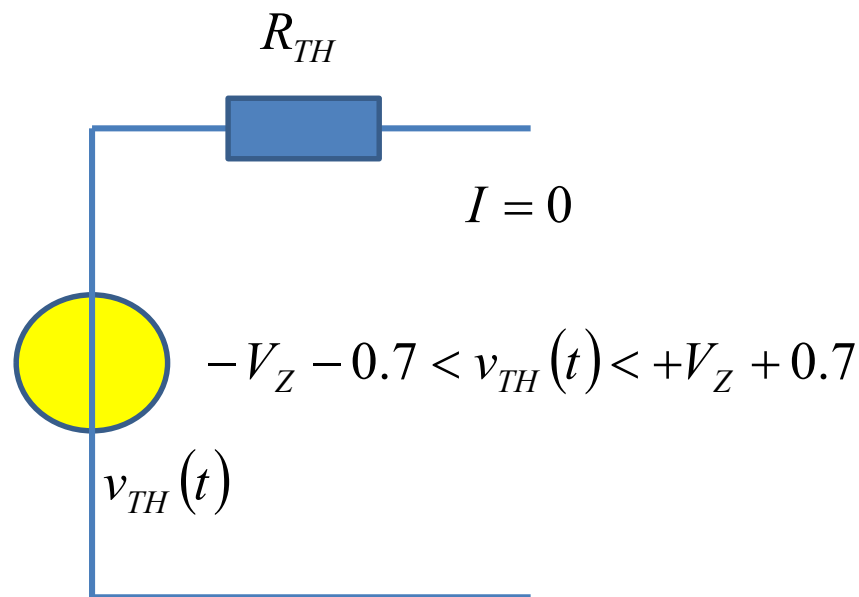
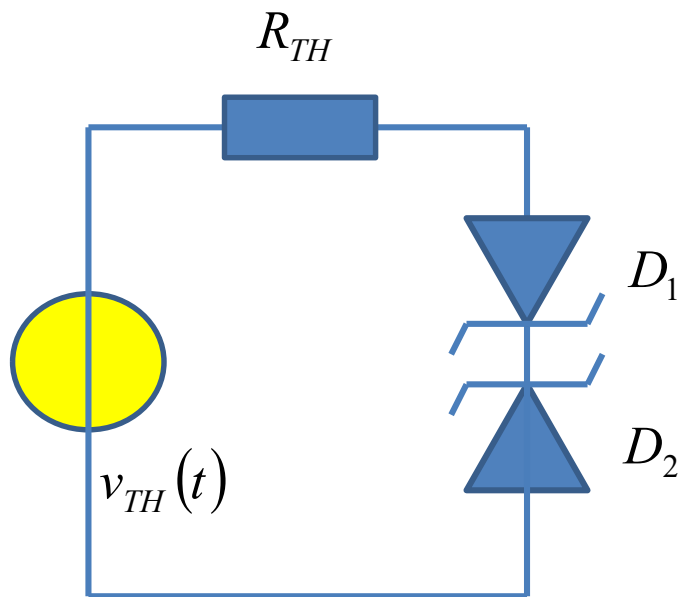

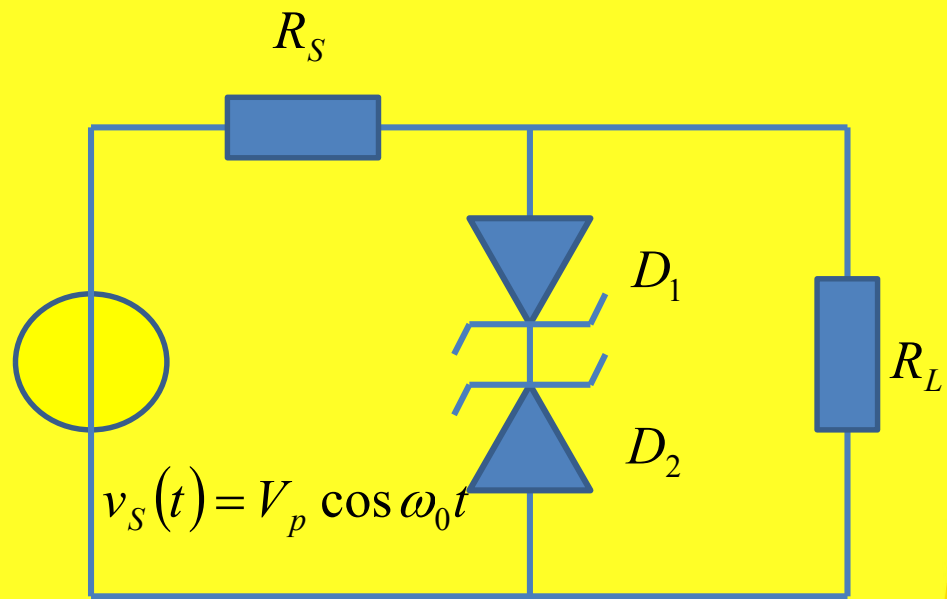

$+V_Z + 0.7$

$-V_Z - 0.7$

v_S 在某个范围之内，输出和输入为线性关系

幅度超过这个范围，则切顶；输入正弦信号幅度极大，输出切顶近似方波

输入输出转移特性曲线

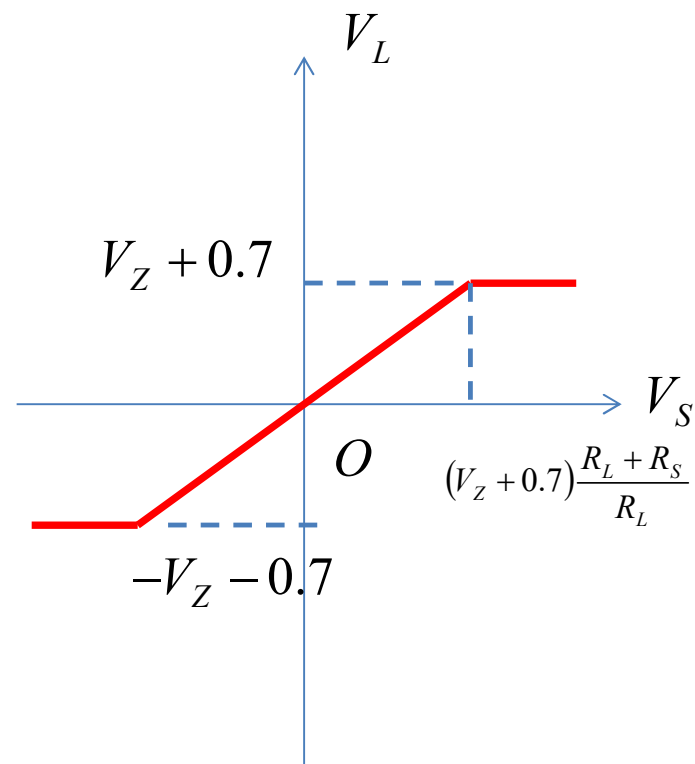
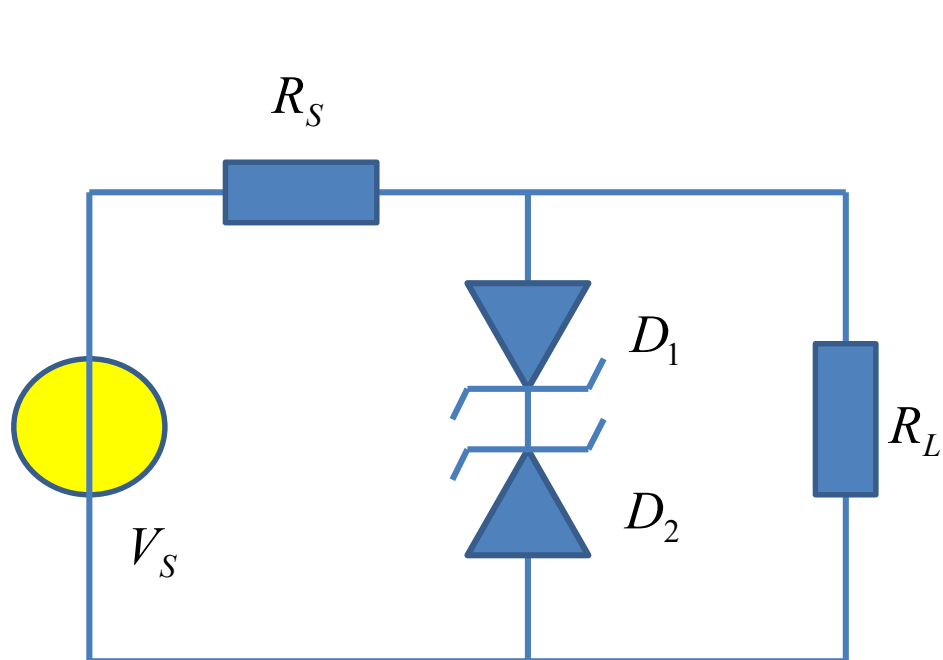

V_S 在某个范围之内，输出和输入为线性关系；幅度超过这个范围，则切顶（饱和）

第9周作业1: NMOS晶体管

- (1) 某NMOSFET的过驱动电压为0.5V, 其饱和电压为多少?
- (2) 该晶体管的 $\beta_n=2\text{mA/V}^2$, 厄利电压为 $V_E=50\text{V}$, 则在 $V_{DS}=1\text{V}$ 时, 漏极电流为多少?
 - 必做: 不考虑厄利效应; 选作: 考虑厄利效应
- (3) 其等效电路模型中的源电流为多少? 源内阻为多少?

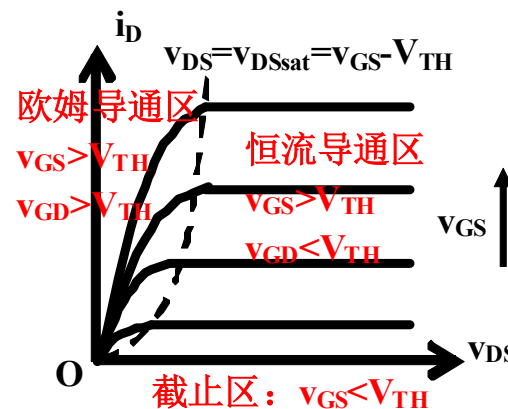
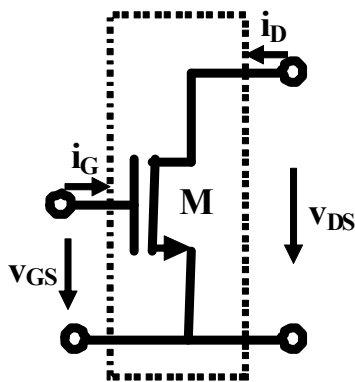
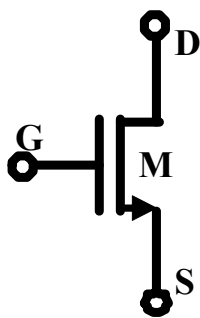

- (1) 某NMOSFET的过驱动电压为0.5V，其饱和电压为多少？
- (2) 该晶体管的 $\beta_n=2\text{mA/V}^2$ ，厄利电压为 $V_E=50\text{V}$ ，则在 $V_{DS}=1\text{V}$ 时，漏极电流为多少？
- (3) 其等效电路模型中的源电流为多少？源内阻为多少？

$V_{od} = V_{GS} - V_{TH} = 0.5\text{V}$ **过驱动电压：只有过驱动， $V_{GS}=V_{TH}+V_{od}$ ，才能有静电荷积累形成的沟道**
 从 V_{GS} 这个角度看：是否导通或者截止

$V_{DS,sat} = V_{GS} - V_{TH} = 0.5\text{V}$ **饱和电压：只要 $V_{DS}>V_{DS,sat}$ ，沟道则夹断，电流呈现饱和特性**
 从 V_{DS} 这个角度看导通是欧姆导通还是恒流导通

$V_{DS} = 1\text{V} > V_{DS,sat} = 0.5\text{V}$ **晶体管位于有源区**

$$I_D = \beta_n (V_{GS} - V_{TH})^2 \left(1 + \frac{V_{DS}}{V_E} \right) = 2 \times 0.5^2 \times \left(1 + \frac{1}{50} \right) = 0.5 \times 1.02 = 0.51\text{mA}$$

$$I_D = \beta_n (V_{GS} - V_{TH})^2 \left(1 + \frac{V_{DS}}{V_E} \right) = I_{D0} \left(1 + \frac{V_{DS}}{V_E} \right) = I_{D0} + \frac{V_{DS}}{V_E / I_{D0}} = I_{D0} + \frac{V_{DS}}{r_{ds}}$$

$$I_{D0} = \beta_n (V_{GS} - V_{TH})^2 = 2 \times 0.5^2 = 0.5\text{mA}$$

$$r_{ds} = \frac{V_E}{I_{D0}} = \frac{50\text{V}}{0.5\text{mA}} = 100\text{k}\Omega$$

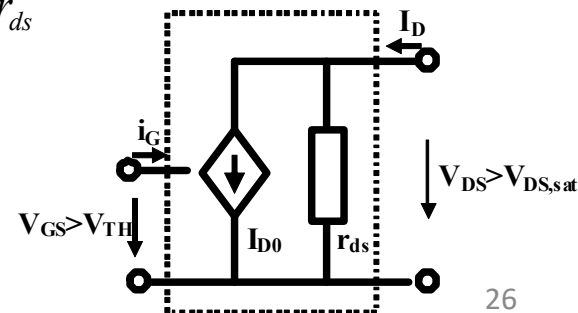

作业2: PMOS晶体管

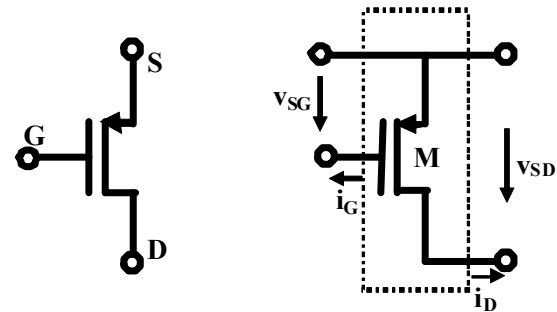

- 画表格，一侧NMOS，一侧PMOS
- (1) 画出NMOS、PMOS晶体管电路符号，二端口网络定义（端口电压、端口电流）
- (2) 写出NMOS、PMOS晶体管的元件约束方程
- (3) 画出伏安特性曲线示意图
- (4) 对于图示的PMOS连接，给出二端口网络的元件约束方程，画出输出端口（有源负载）伏安特性曲线示意图

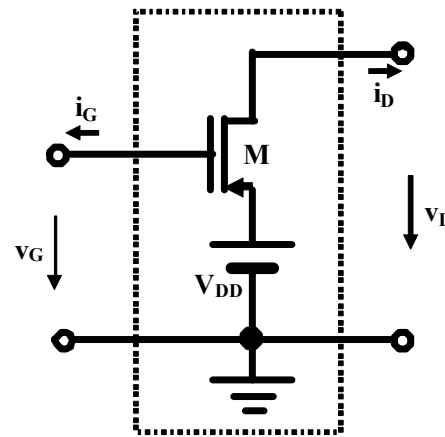
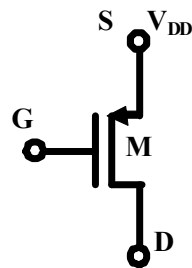

有源负载：可向外提供能量，具有非线性内阻的电压源， v_G 固定则可作为NMOS的负载， v_G 变化则可实现PMOS反相功能

源：源关联参考方向

NMOS和PMOS

	电路符号	二端口网络定义	元件约束条件
NMOS			$i_D = \begin{cases} 0 & v_{GS} < V_{TH,n} \\ 2\beta_n((v_{GS} - V_{TH,n})v_{DS} - 0.5v_{DS}^2) & v_{GS} > V_{TH,n}, v_{GD} > V_{TH,n} \\ \beta_n(v_{GS} - V_{TH,n})^2(1 + \lambda_n v_{DS}) & v_{GS} > V_{TH,n}, v_{GD} < V_{TH,n} \end{cases}$
PMOS			$i_D = \begin{cases} 0 & v_{SG} < V_{TH,p} \\ 2\beta_p((v_{SG} - V_{TH,p})v_{SD} - 0.5v_{SD}^2) & v_{SG} > V_{TH,p}, v_{DG} > V_{TH,p} \\ \beta_p(v_{SG} - V_{TH,p})^2(1 + \lambda_p v_{SD}) & v_{SG} > V_{TH,p}, v_{DG} < V_{TH,p} \end{cases}$

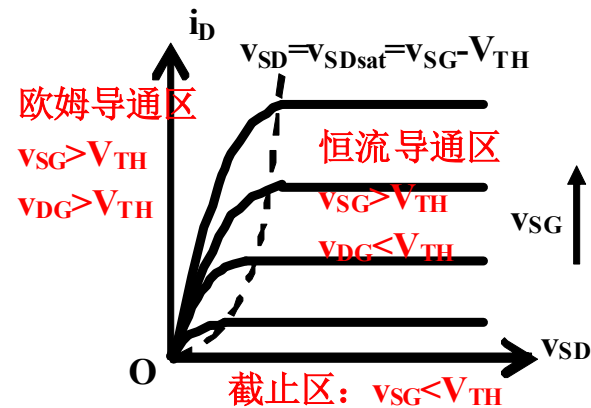
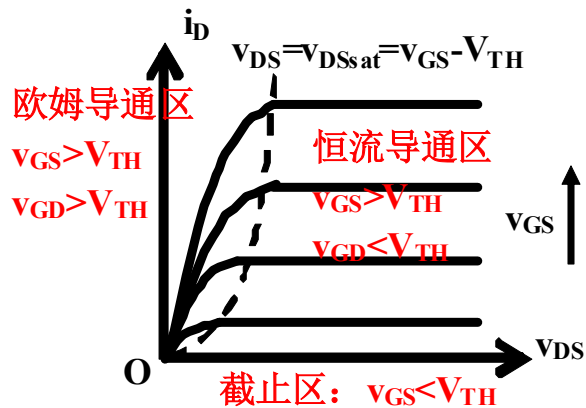

函数平移和反褶

- 函数平移
- 函数反褶

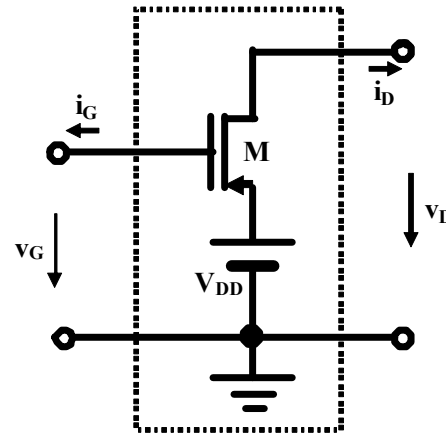
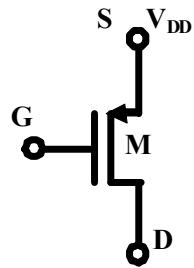

函数移位

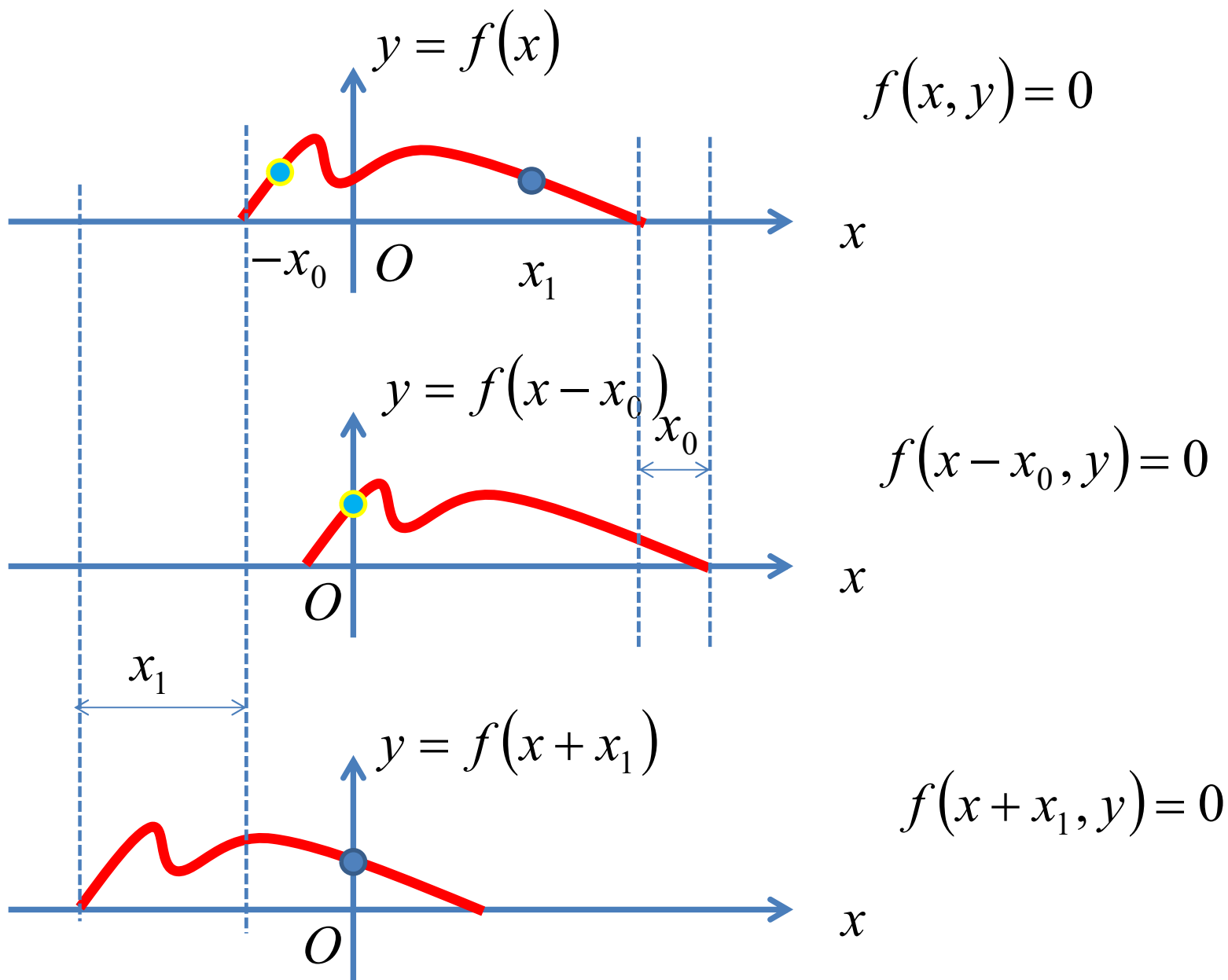

函数反褶

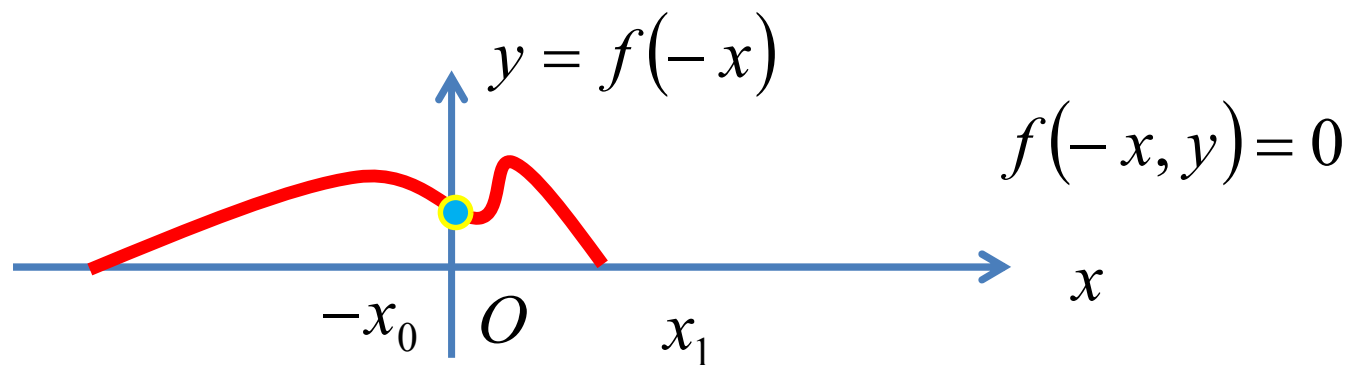
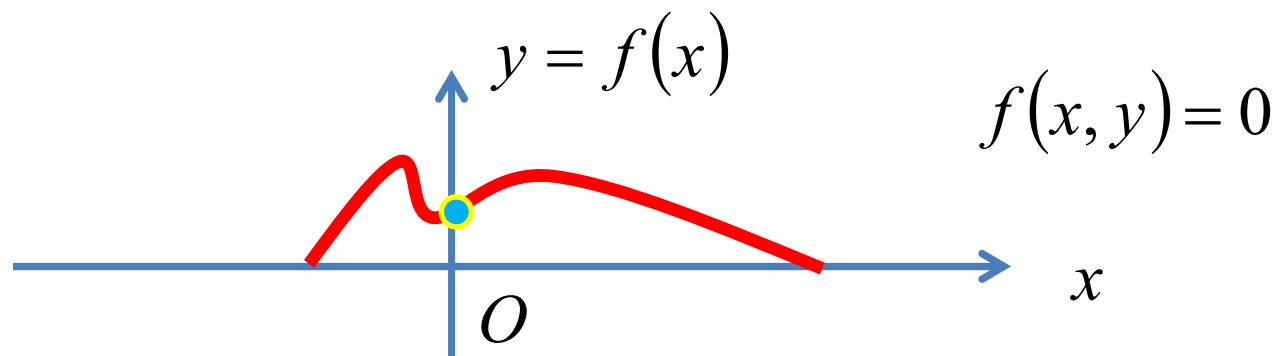

电路例：移位

$$f(x) = \frac{x}{R_S}$$

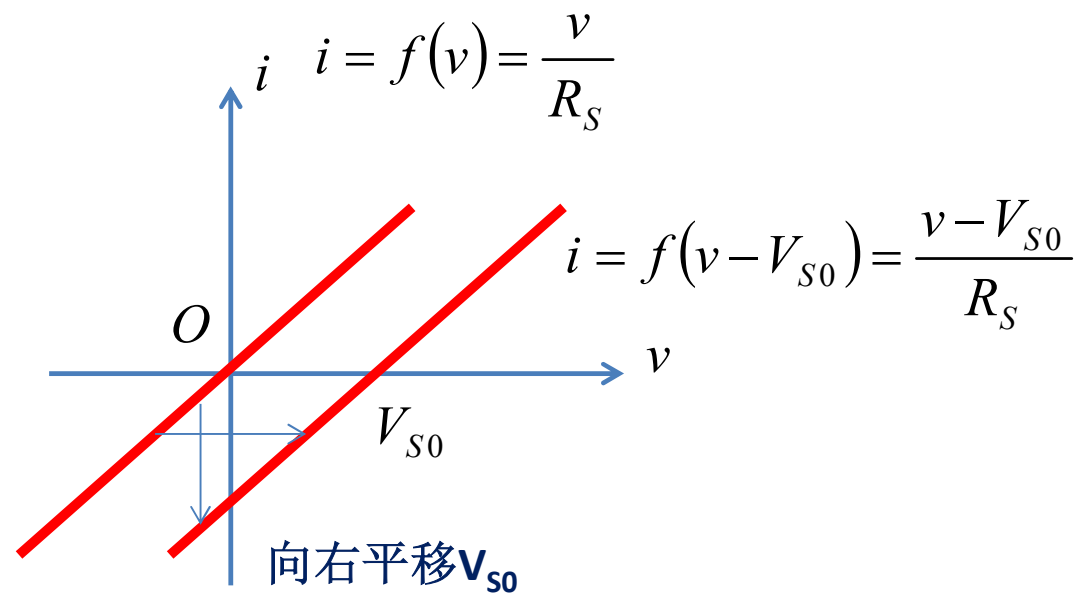
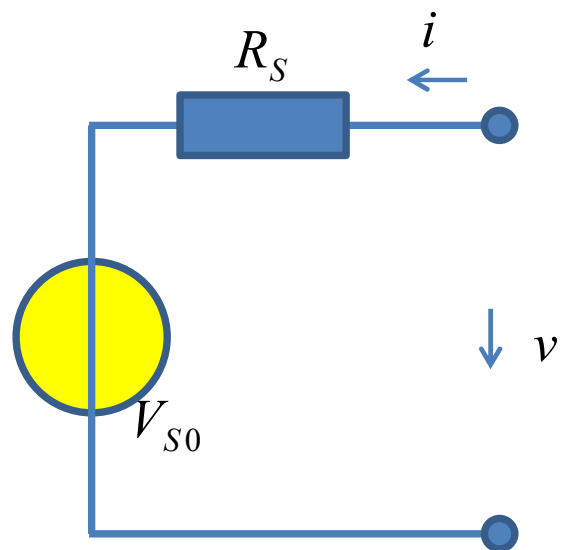

$$v = V_{S0} + iR_S$$

电阻的基础上，加恒压源，向右平移

$$\frac{v}{R_S} = \frac{V_{S0}}{R_S} + i = i + I_{S0}$$

电阻的基础上，加恒流源，向下平移

电路例： 反褶

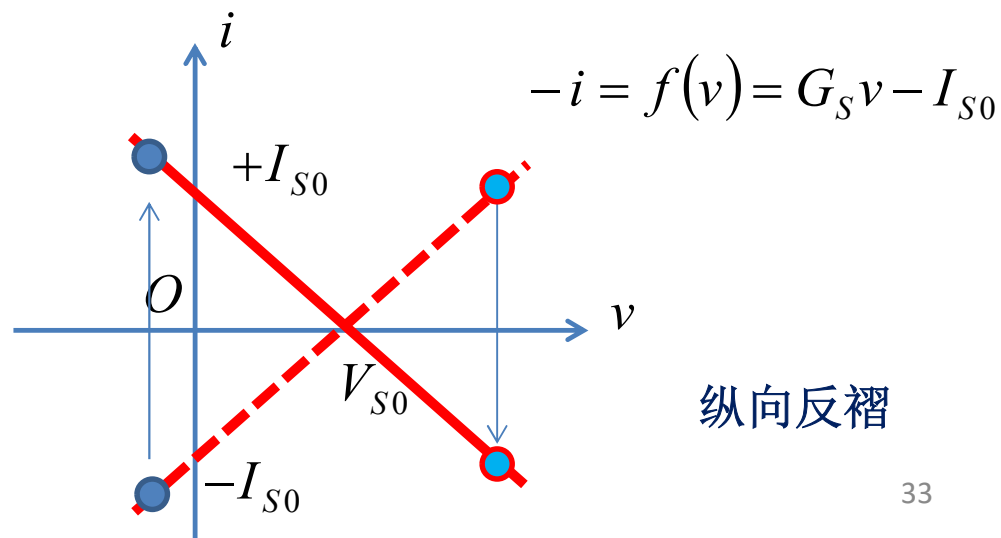
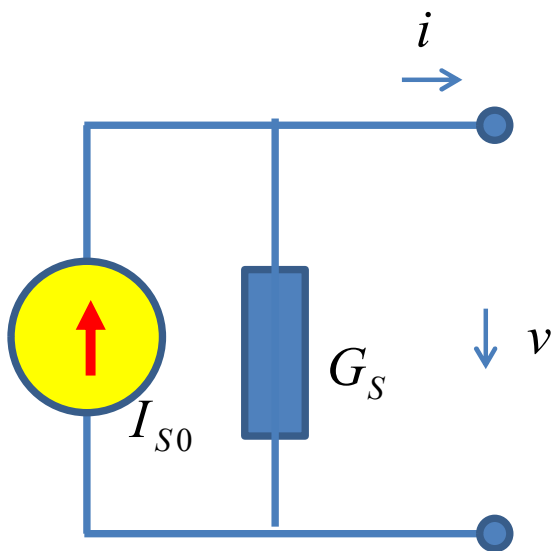
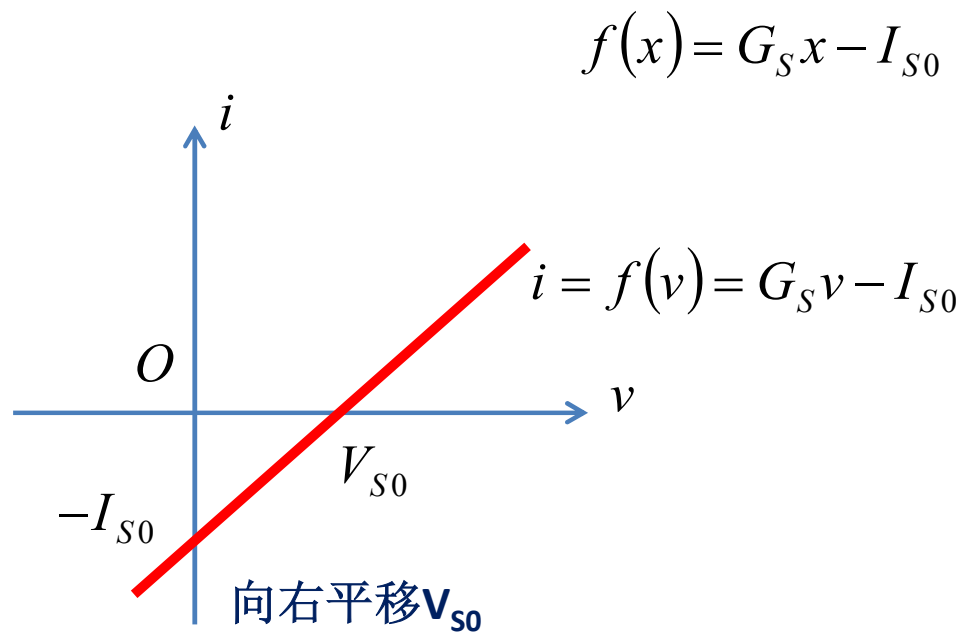
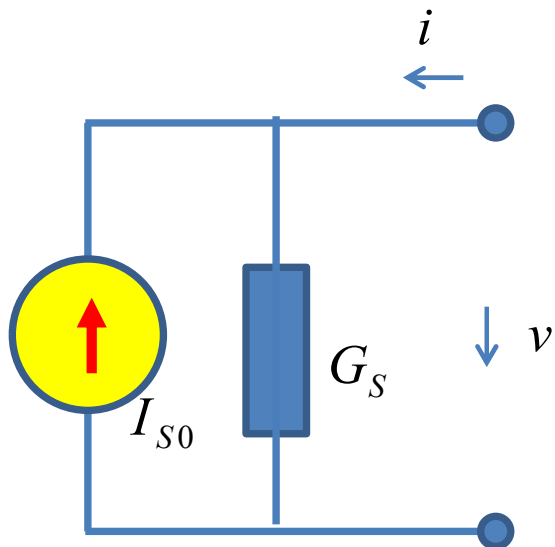

函数平移与反褶运算

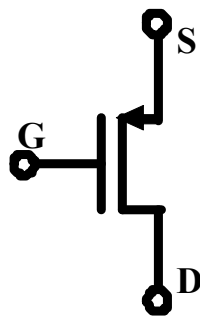

$$V_{DD} = 5V$$

$$V_{TH} = 1V$$

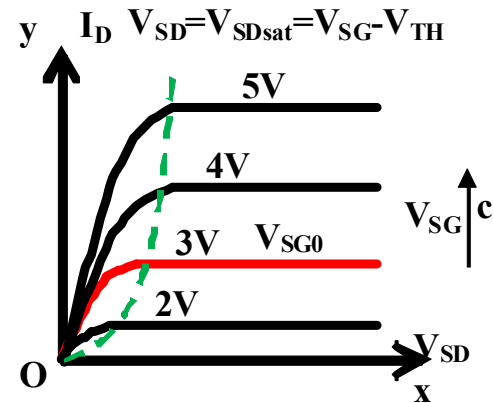
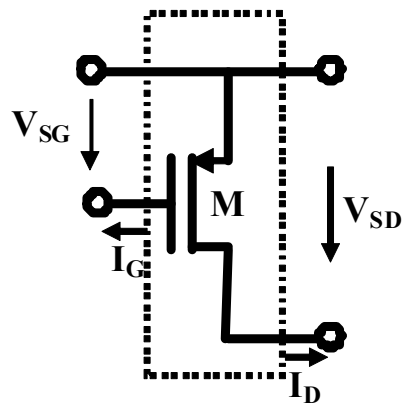

无源

$$I_D = f(V_{SG}, V_{SD}) = f(c, x) = y$$

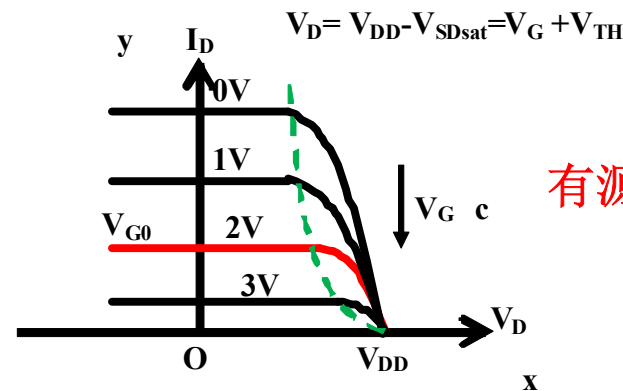
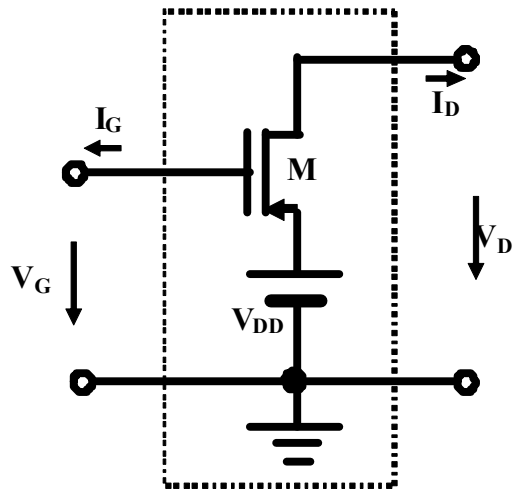
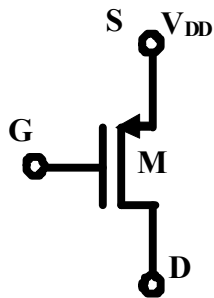

有源

$$I_D = f(V_{DD} - V_G, V_{DD} - V_D) = f(V_{DD} - c, V_{DD} - x) = y$$

先反褶再平移

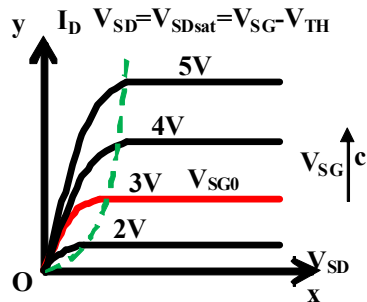
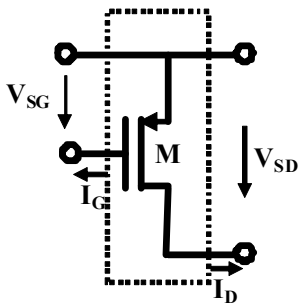
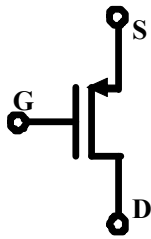

晶体管是非线性电阻
关联参考方向下，DS端口伏安特性全部位于一、三象限，只能吸收功率而无法释放功率

$$i_D = \begin{cases} 0 & v_{SG} < V_{TH,p} \\ 2\beta_p \left((v_{SG} - V_{TH,p}) v_{SD} - 0.5v_{SD}^2 \right) & v_{SG} > V_{TH,p}, v_{DG} > V_{TH,p} \\ \beta_p (v_{SG} - V_{TH,p})^2 (1 + \lambda_p v_{SD}) & v_{SG} > V_{TH,p}, v_{DG} < V_{TH,p} \end{cases}$$

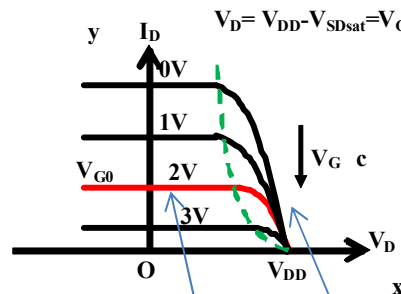
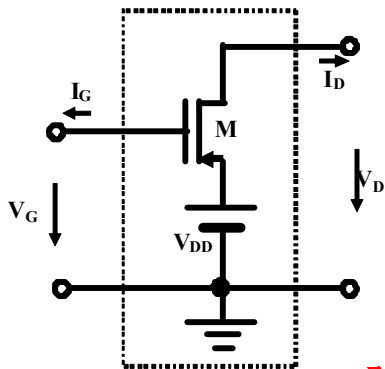
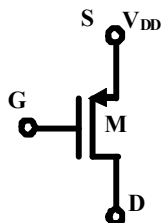

对外等效为恒流源

对外等效为有内阻的戴维南源

晶体管沟道电阻是电压源的非线性内阻，源关联参考方向下，DS端口伏安特性存在位于第一象限的区段，可以在此区段向外释放能量

$$i_D = \begin{cases} 0 & v_G > V_{DD} - V_{TH,p} \\ 2\beta_p \left((V_{DD} - v_G - V_{TH,p})(V_{DD} - v_D) - 0.5(V_{DD} - v_D)^2 \right) & v_G < V_{DD} - V_{TH,p}, v_D > V_{TH,p} + v_G \\ \beta_p (V_{DD} - v_G - V_{TH,p})^2 (1 + \lambda_p (V_{DD} - v_D)) & v_G < V_{DD} - V_{TH,p}, v_D < V_{TH,p} + v_G \end{cases}$$

作业3

PMOS反相器

- 请用分段折线法分析如图所示PMOS反相器电路，画出其输入-输出电压转移特性曲线示意图

– NMOSFET参量为

$$\beta_n = 2.5 \text{mA/V}^2, V_{THn} = 0.8 \text{V};$$

PMOSFET参量为

$$\beta_p = 1 \text{mA/V}^2, V_{THp} = 0.7 \text{V};$$

偏置电阻 $R_D = 3.3 \text{k}\Omega$ ，电源电压 $V_{DD} = 3.3 \text{V}$

- 假设通过某种偏置方式，使得图b所示NMOSFET的栅极电压被设置为 $V_{G0} = 1.3 \text{V}$ ，源栅电压为 $V_{GSn} = 1.3 \text{V}$ ，过驱动电压为 $V_{odn} = V_{GSn} - V_{THn} = 0.5 \text{V}$ 。

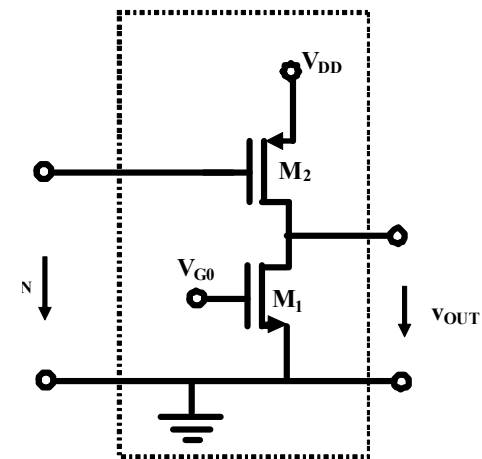
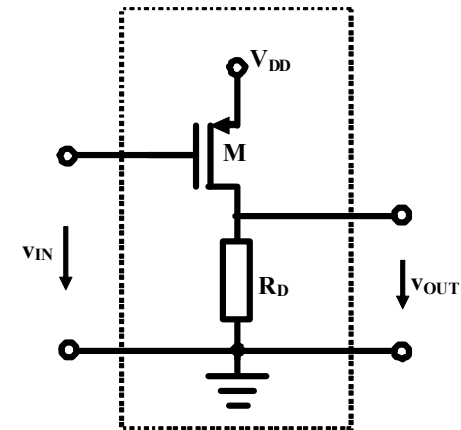

PMOS反相器：图解法原理分析

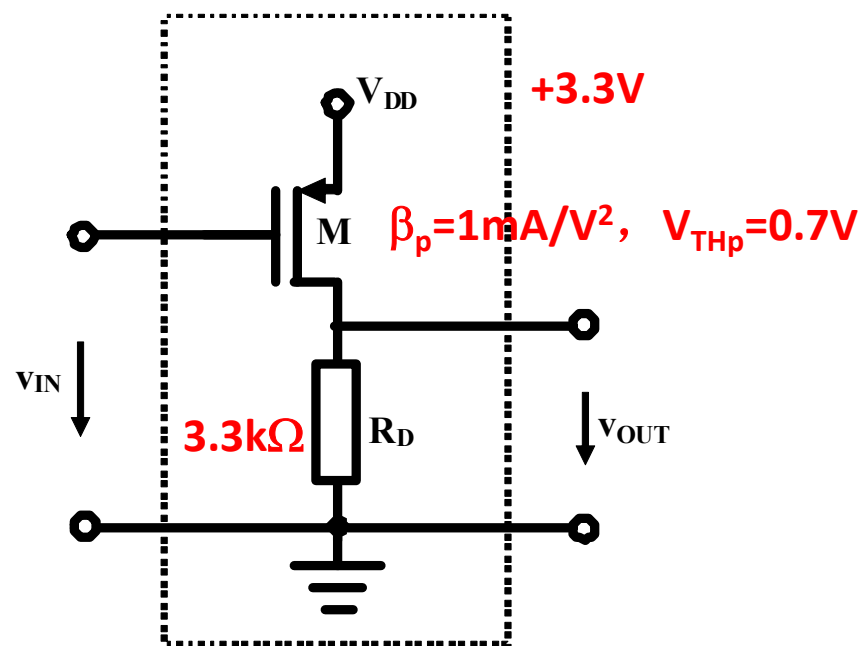
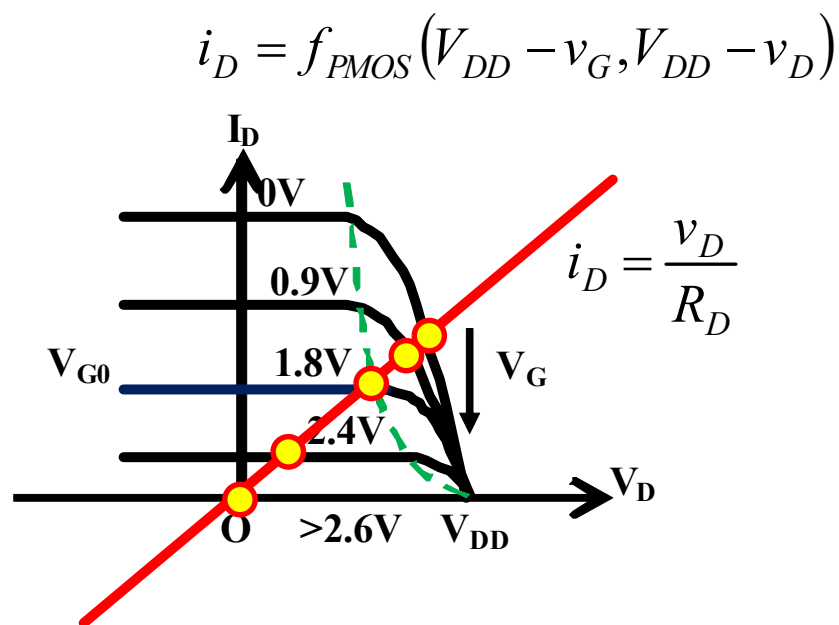

随着输入电压 $v_{IN} = v_G$ 的增加，输出电压 $v_{OUT} = v_D$ 是降低的：反相功能

分段折线：PMOS截止

$$v_{IN} > V_{DD} - V_{TH,p} = 3.3 - 0.7 = 2.6V$$

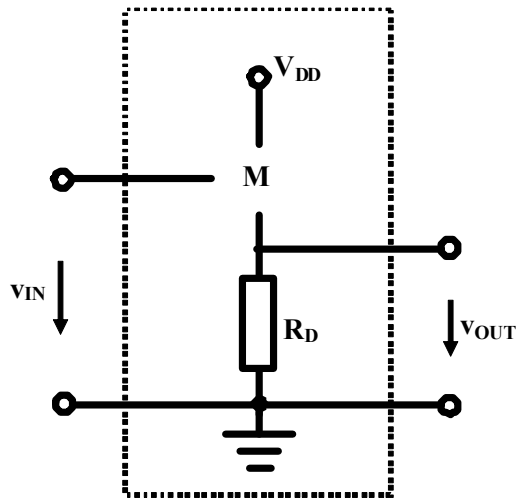
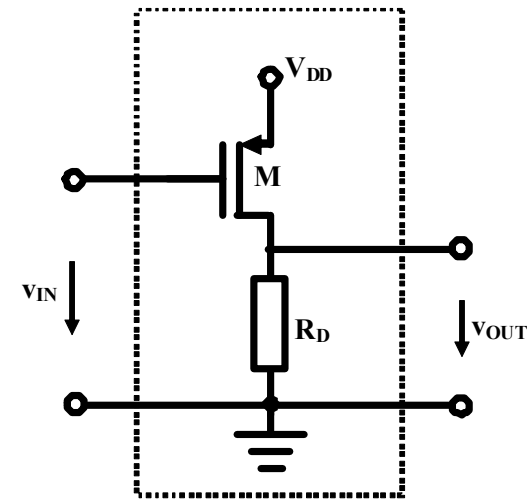

$$v_{OUT} = 0$$

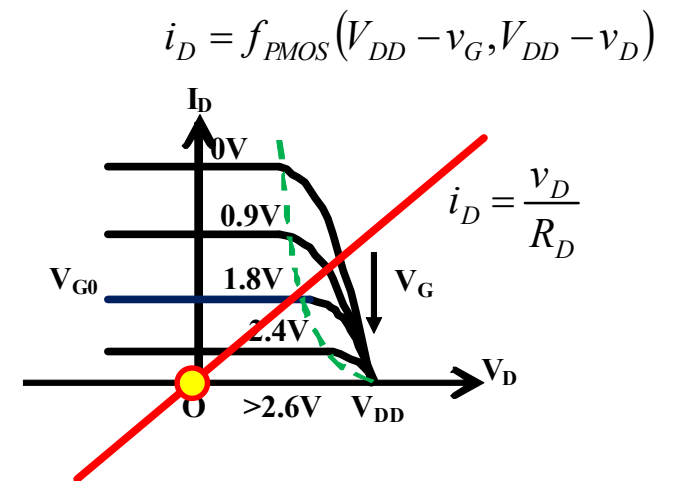

分段折线：PMOS恒流

$$v_{IN} < V_{DD} - V_{TH,p} = 3.3 - 0.7 = 2.6V$$

$$v_{OUT} = v_D < V_{TH,p} + v_G = v_{IN} + 0.7$$

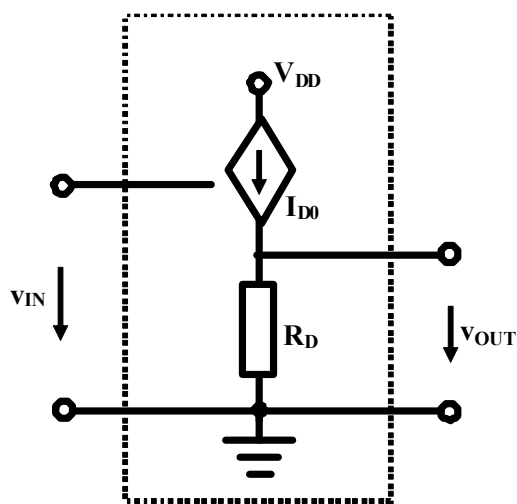
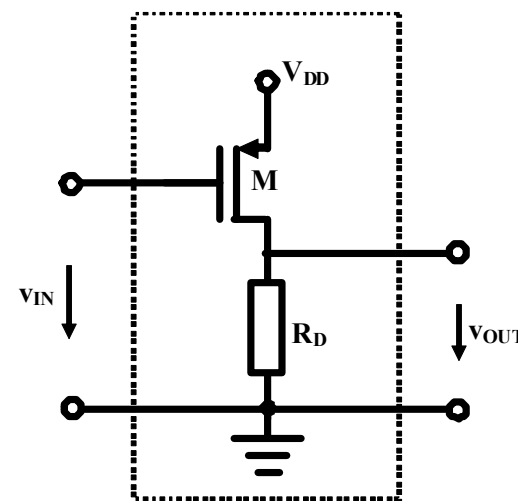

$$I_{D0} = \beta_p (V_{DD} - v_{IN} - V_{TH,p})^2 = (2.6 - v_{IN})^2 (mA)$$

$$\begin{aligned} v_{OUT} &= I_{D0} R_D \\ &= \beta_p (V_{DD} - v_{IN} - V_{TH,p})^2 \\ &= 3.3 \times (2.6 - v_{IN})^2 \end{aligned}$$

输入降低，输出提高

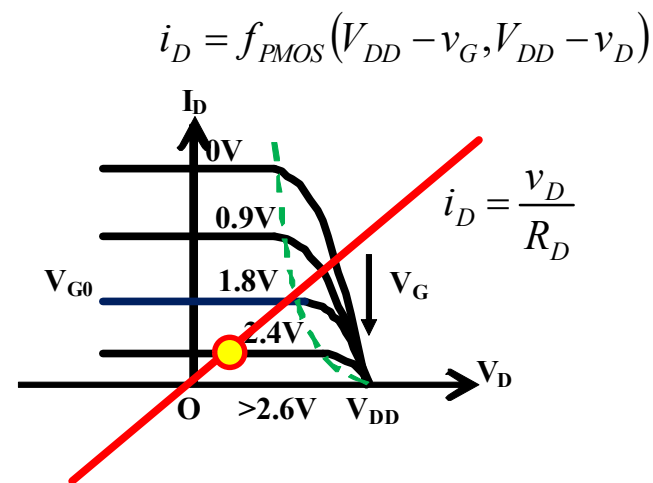

分段折线

恒流欧姆分界

$$v_{IN} < V_{DD} - V_{TH,p} = 3.3 - 0.7 = 2.6V$$

$$v_{OUT} = v_D < V_{TH,p} + v_G = v_{IN} + 0.7$$

$$v_{OUT} = \beta_p (V_{DD} - v_{IN} - V_{TH,p})^2 = 3.3 \times (2.6 - v_{IN})^2$$

输入降低，输出提高

$$v_{OUT} = \beta_p (V_{DD} - v_{IN} - V_{TH,p})^2 = V_{TH,p} + v_{IN}$$

$$= 3.3 \times (2.6 - v_{IN})^2 = v_{IN} + 0.7$$

$$3.3 \times (2.6 - v_{IN})^2 - v_{IN} - 0.7 = 0$$

$$3.3v_{IN}^2 - 18.16v_{IN} + 21.608 = 0$$

$$v_{IN} = 1.74V, 3.76V$$

$$v_{IN,k} = 1.74V$$

$$v_{OUT,k} = 2.44V$$

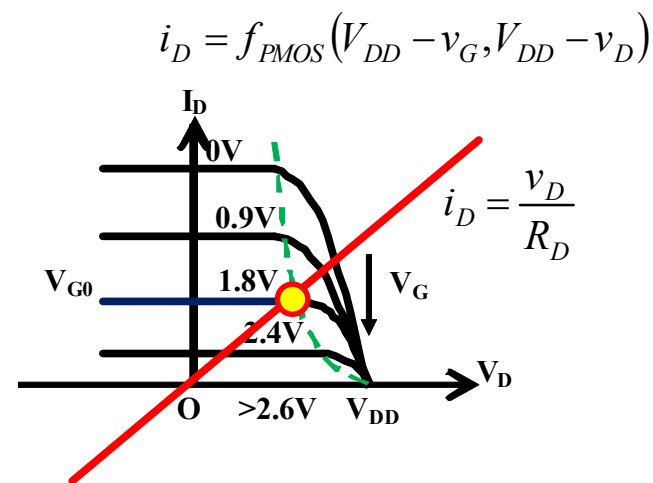
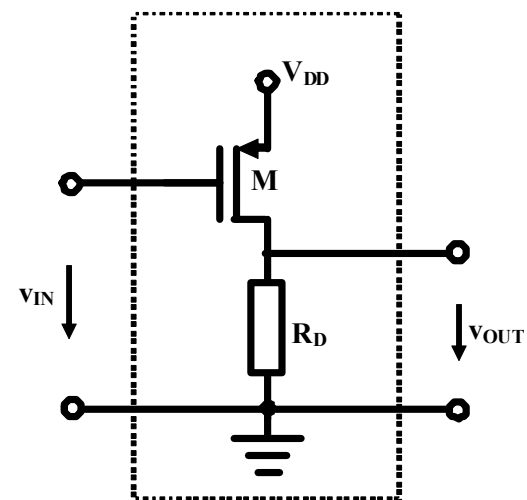

分段折线：PMOS欧姆

$$v_{IN} < v_{IN,k} = 1.74V$$

$$v_{OUT} = v_D > V_{TH,p} + v_G = v_{IN} + 0.7$$

$$i_D = 2\beta_p \left((V_{DD} - v_G - V_{TH,p})(V_{DD} - v_D) - 0.5(V_{DD} - v_D)^2 \right)$$

$$\approx 2\beta_p (V_{DD} - v_{IN} - V_{TH,p})(V_{DD} - v_{OUT}) = \frac{V_{DD} - v_{OUT}}{r_{on}}$$

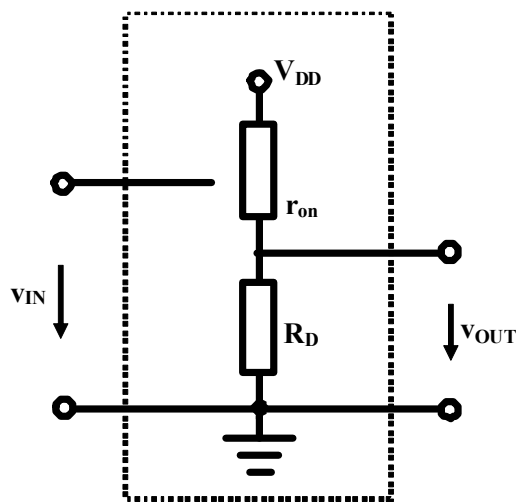
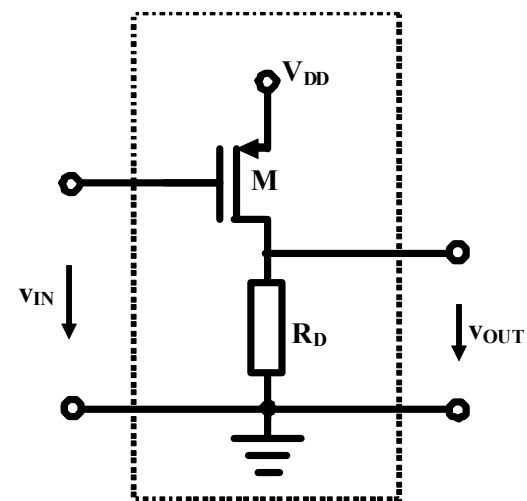

$$v_{OUT} = \frac{R_D}{R_D + r_{on}} V_{DD}$$

$$= \frac{2\beta_p (V_{DD} - v_{IN} - V_{TH,p}) R_D}{2\beta_p (V_{DD} - v_{IN} - V_{TH,p}) R_D + 1} V_{DD}$$

$$= \frac{6.6 \times (2.6 - v_{IN})}{6.6 \times (2.6 - v_{IN}) + 1} V_{DD}$$

$$= \frac{2.6 - v_{IN}}{2.75 - v_{IN}} \times 3.3$$

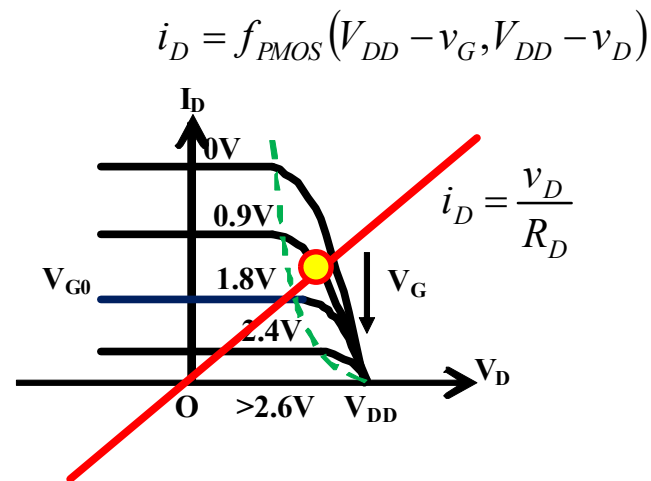

分段折线分析结果

$$v_{OUT} = \begin{cases} \frac{2.6 - v_{IN}}{2.75 - v_{IN}} \times 3.3 & v_{IN} < 1.74V \quad \text{PMOS欧姆导通} \\ 3.3 \times (2.6 - v_{IN})^2 & 1.74V < v_{IN} < 2.6V \quad \text{PMOS恒流导通} \\ 0 & v_{IN} > 2.6V \quad \text{PMOS截止} \end{cases}$$

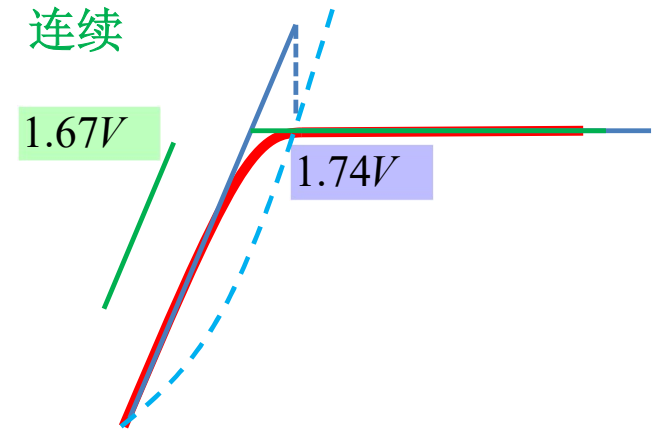
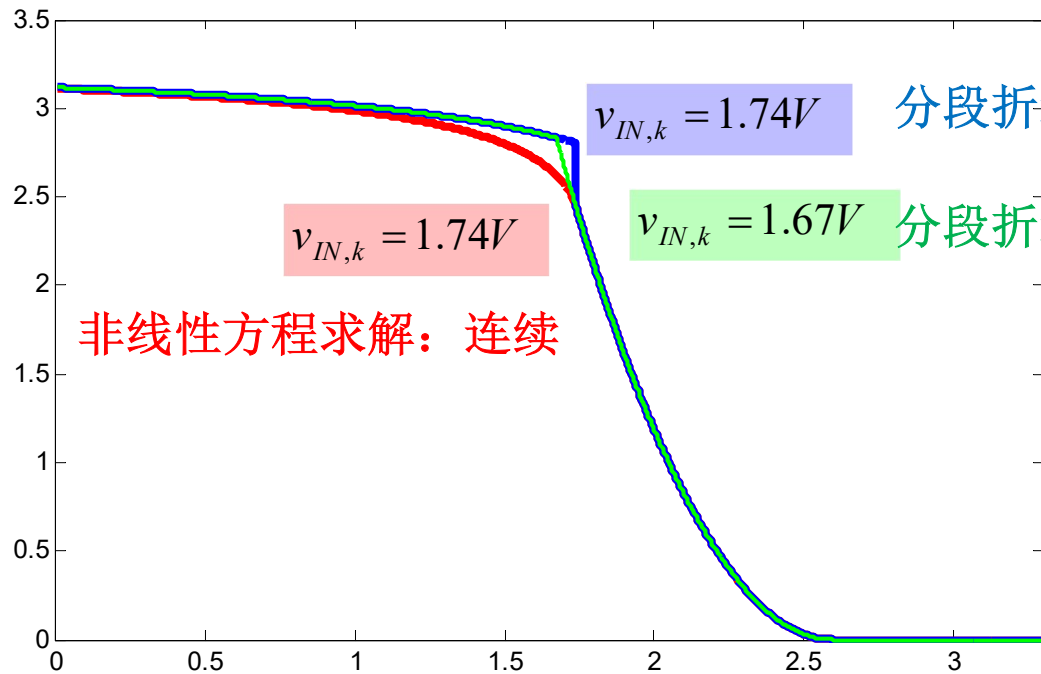
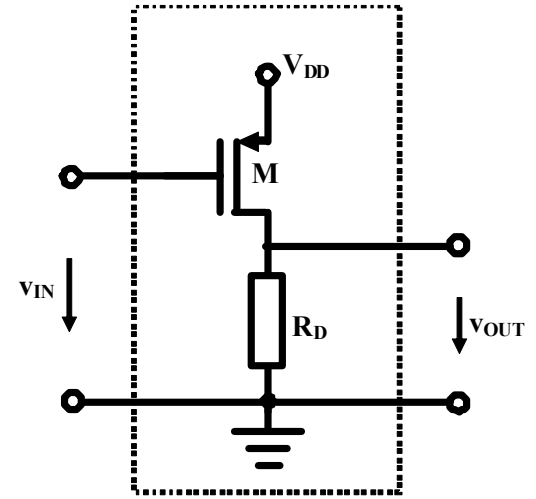

作业4 负反馈降低不确定性

- (1) 验证例4设计: 确认两个电流源输出电流都是**1mA**; 确认其等效电路为恒流源
- (2) 由于工艺参数不确定及环境温度度的变化, 使得PMOSFET的工艺参量 $\mu_p C_{ox}$ 偏离设计值 **$100\mu A/V^2$** -5%, 请分析确认, 图示两个电路结构的等效恒流源输出, 有负反馈电阻的输出电流比没有负反馈电阻的输出电流更稳定, 更接近设计值**1mA**

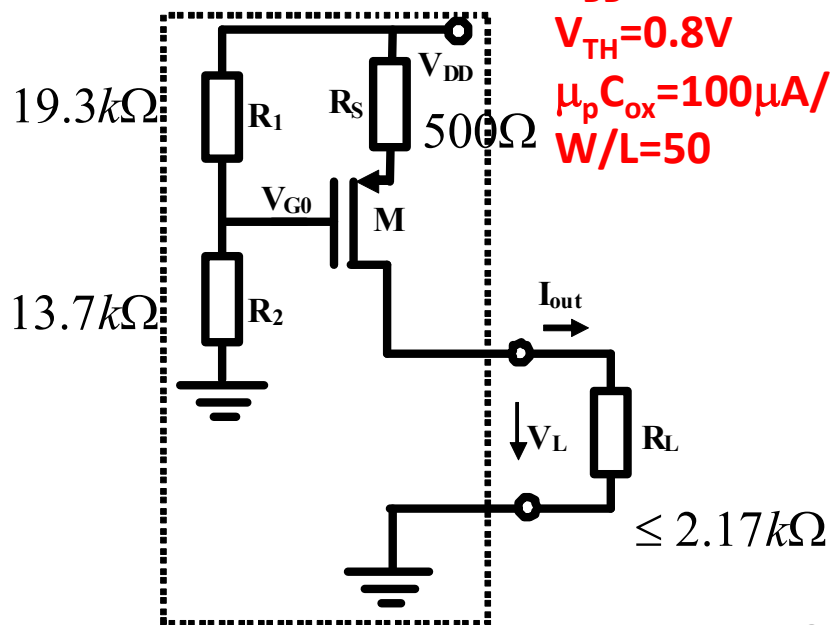
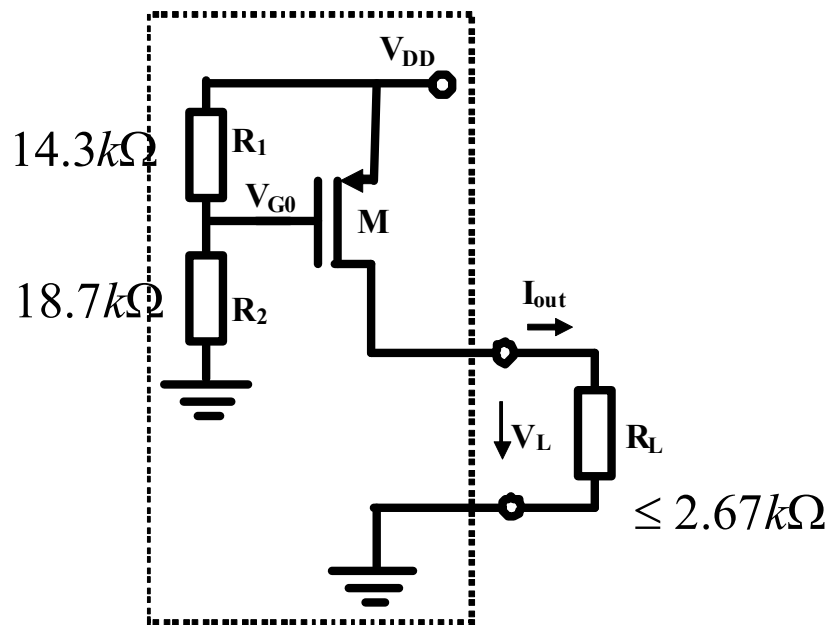

$V_{DD}=3.3V$
 $V_{TH}=0.8V$
 $\mu_p C_{ox}=100\mu A/V^2$
 $W/L=50$

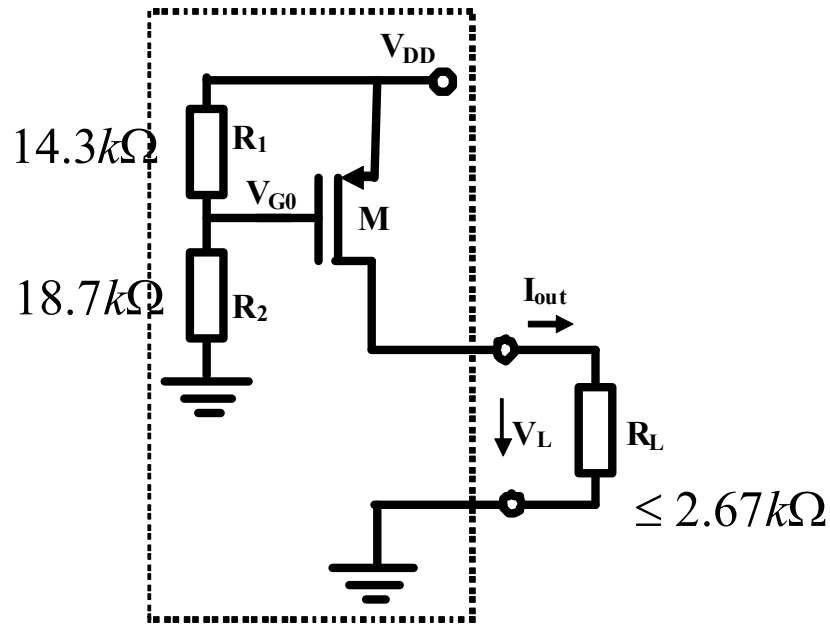

$$V_{G0} = \frac{18.7}{18.7 + 14.3} \times 3.3 = 1.87V$$

$$V_{SG} = V_{DD} - V_{G0} = 3.3 - 1.87 = 1.43V$$

$$I_D = \frac{1}{2} \mu_p C_{ox} \frac{W}{L} (V_{SG} - V_{TH})^2$$

$$= \frac{1}{2} \times 100 \mu \times 50 \times (1.43 - 0.8)^2 = 0.99mA \approx 1mA$$

$$V_{G0} = \frac{13.7}{13.7 + 19.3} \times 3.3 = 1.37V$$

$$V_{SG} = V_{DD} - I_D R_S - V_{G0} = 1.93 - I_D R_S$$

$$I_D = \frac{1}{2} \mu_p C_{ox} \frac{W}{L} (V_{SG} - V_{TH})^2$$

$$= \frac{1}{2} \times 100 \mu \times 50 \times (1.93 - I_D R_S - 0.8)^2 = 2.5 \times (1.13 - 0.5 \cdot I_D)^2$$

$$1.6I_D = (2.26 - I_D)^2 = 5.1076 - 4.52I_D + I_D^2$$

$$5.1076 - 6.12I_D + I_D^2 = 0$$

$$I_D = 0.997mA, 5.123mA$$

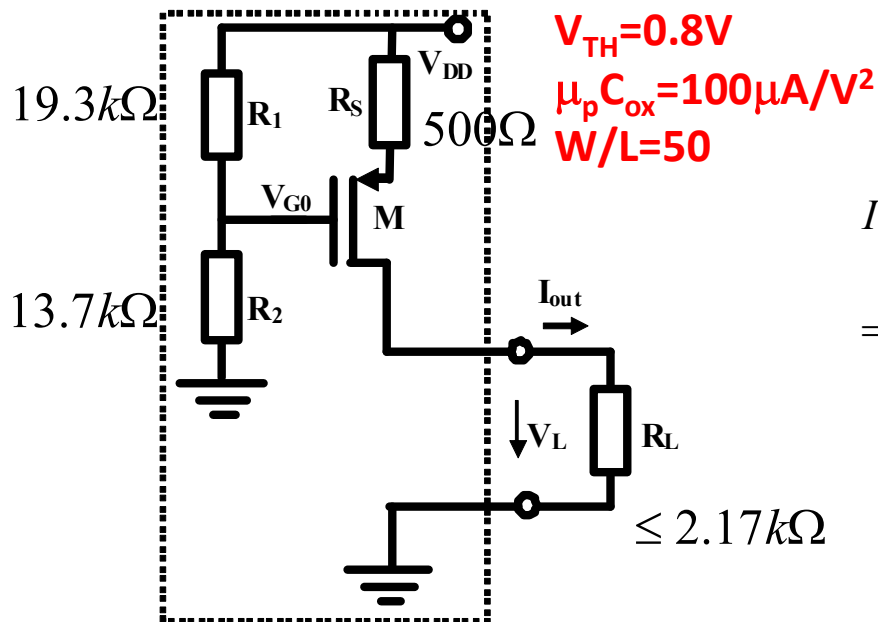

$V_{DD} = 3.3V$
 $V_{TH} = 0.8V$
 $\mu_p C_{ox} = 100 \mu A/V^2$
 $W/L = 50$

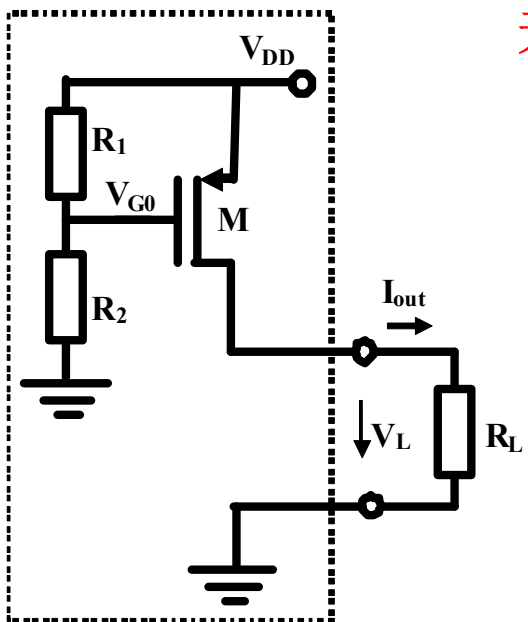

无负反馈

$$I_D = \frac{1}{2} \mu_p C_{ox} \frac{W}{L} (V_{SG} - V_{TH})^2 = \frac{1}{2} K_p \frac{W}{L} (V_{SG} - V_{TH})^2$$

$$S_{K_p}^{I_D} = \frac{\partial I_D}{\partial K_p} \frac{K_p}{I_D} = \frac{1}{2} \frac{W}{L} (V_{SG} - V_{TH})^2 \frac{K_p}{I_D} = 1$$

有串联负反馈电阻

$$I_D = \frac{1}{2} \mu_p C_{ox} \frac{W}{L} (V_{SG} - V_{TH})^2 = \frac{1}{2} K_p \frac{W}{L} (\eta V_{DD} - I_D R_S - V_{TH})^2$$

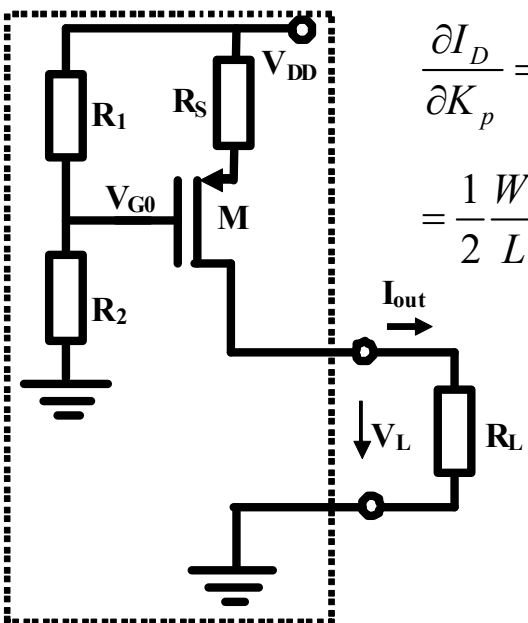

$$\frac{\partial I_D}{\partial K_p} = \frac{1}{2} \frac{W}{L} (\eta V_{DD} - I_D R_S - V_{TH})^2 + \frac{1}{2} K_p \frac{W}{L} 2(\eta V_{DD} - I_D R_S - V_{TH}) \left(-R_S \frac{\partial I_D}{\partial K_p} \right)$$

$$= \frac{1}{2} \frac{W}{L} (\eta V_{DD} - I_D R_S - V_{TH})^2 + g_m \left(-R_S \frac{\partial I_D}{\partial K_p} \right)$$

$$g_m = \frac{\partial I_D}{\partial V_{SG}}$$

$$\frac{\partial I_D}{\partial K_p} = \frac{\frac{1}{2} \frac{W}{L} (\eta V_{DD} - I_D R_S - V_{TH})^2}{1 + g_m R_S}$$

$$S_{K_p}^{I_D} = \frac{\partial I_D}{\partial K_p} \frac{K_p}{I_D} = \frac{1}{1 + g_m R_S}$$

灵敏度因负反馈降低

变化百分比

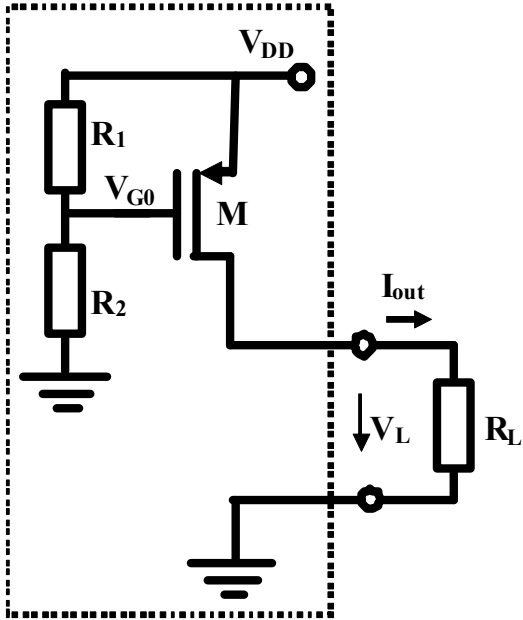

$$S_{K_p}^{I_D} = \frac{\partial I_D}{\partial K_p} \frac{K_p}{I_D} = 1$$

$$\frac{\Delta I_D}{I_D} = S_{K_p}^{I_D} \frac{\Delta K_p}{K_p} = 1 \times (-5\%) = -5\%$$

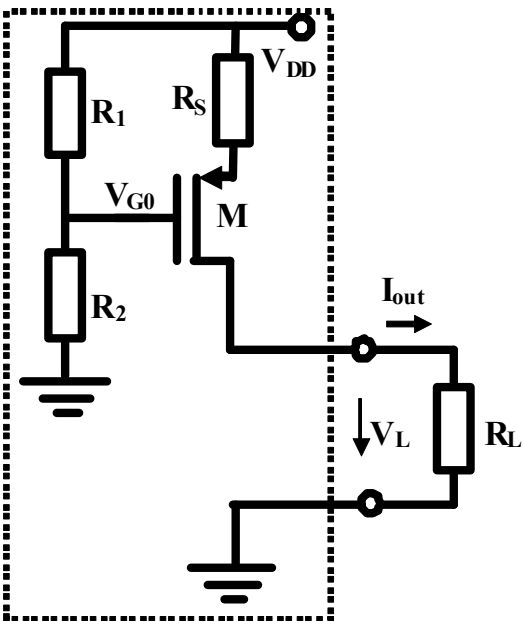

$$I_D = \frac{1}{2} \mu_p C_{ox} \frac{W}{L} (V_{SG} - V_{TH})^2 = \frac{1}{2} K_p \frac{W}{L} (V_{SG} - V_{TH})^2$$

$$g_m = \frac{\partial I_D}{\partial V_{SG}} = \mu_p C_{ox} \frac{W}{L} (V_{SG} - V_{TH}) = \frac{2I_D}{V_{SG} - V_{TH}} = \frac{2 \times 1mA}{1.43 - 0.8} = 3.17mS$$

$$S_{K_p}^{I_D} = \frac{\partial I_D}{\partial K_p} \frac{K_p}{I_D} = \frac{1}{1 + g_m R_S} = \frac{1}{1 + 3.17mS \times 0.5k\Omega} = \frac{1}{1 + 1.59} = 0.39$$

$$\frac{\Delta I_D}{I_D} = S_{K_p}^{I_D} \frac{\Delta K_p}{K_p} = 0.39 \times (-5\%) = -1.9\%$$

灵敏度代表影响力

$$S_{x_i}^y = \frac{\Delta y / y}{\Delta x_i / x_i} \stackrel{\Delta x_i \rightarrow 0}{=} \frac{x_i}{y} \frac{\partial y}{\partial x_i}$$

设计值 实际制作偏离设计值

$$y = f(x_1, x_2, \dots, x_n) = f(x_{10} + \Delta x_1, x_{20} + \Delta x_2, \dots, x_{n0} + \Delta x_n)$$
$$= f(x_{10}, x_{20}, \dots, x_{n0}) + \frac{\partial f}{\partial x_1} \Delta x_1 + \frac{\partial f}{\partial x_2} \Delta x_2 + \dots + \frac{\partial f}{\partial x_n} \Delta x_n + h.o.t$$

$$\Delta y = y - y_0 \approx \frac{\partial f}{\partial x_1} \Delta x_1 + \frac{\partial f}{\partial x_2} \Delta x_2 + \dots + \frac{\partial f}{\partial x_n} \Delta x_n$$

导致输出偏离设计值

$$\frac{\Delta y}{y_0} \approx \frac{\partial f}{\partial x_1} \frac{x_{10}}{y_0} \frac{\Delta x_1}{x_{10}} + \frac{\partial f}{\partial x_2} \frac{x_{20}}{y_0} \frac{\Delta x_2}{x_{20}} + \dots + \frac{\partial f}{\partial x_n} \frac{x_{n0}}{y_0} \frac{\Delta x_n}{x_{n0}}$$

$$\frac{\Delta y}{y_0} = S_{x_1}^y \frac{\Delta x_1}{x_{10}} + S_{x_2}^y \frac{\Delta x_2}{x_{20}} + \dots + S_{x_n}^y \frac{\Delta x_n}{x_{n0}}$$

对于极度不稳定因素如 β ，电路设计时应确保其灵敏度最小，从而提高系统稳定性，负反馈措施可以有效降低灵敏度

灵敏度：该因素对最终输出的影响力大小

单管放大实验电路的说明

- 实验目的
 - 掌握放大电路直流工作点的调整与测量方法
 - 掌握放大电路主要性能指标的测量方法
 - 了解直流工作点对放大电路动态特性的影响
 - 掌握发射极负反馈电阻对放大电路性能的影响
 - 了解信号源内阻 R_s 对放大电路频带（上限截止频率 f_H ）的影响

实验电路

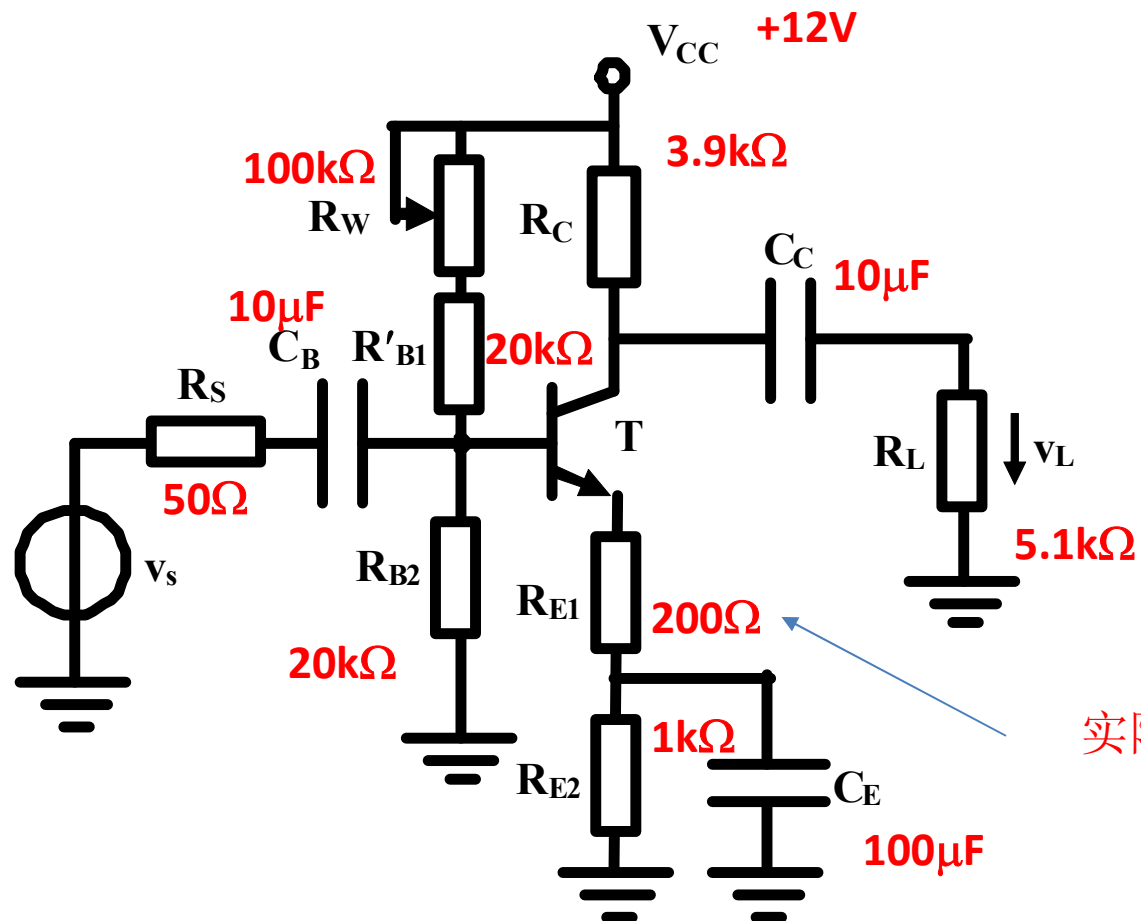

器件功能描述

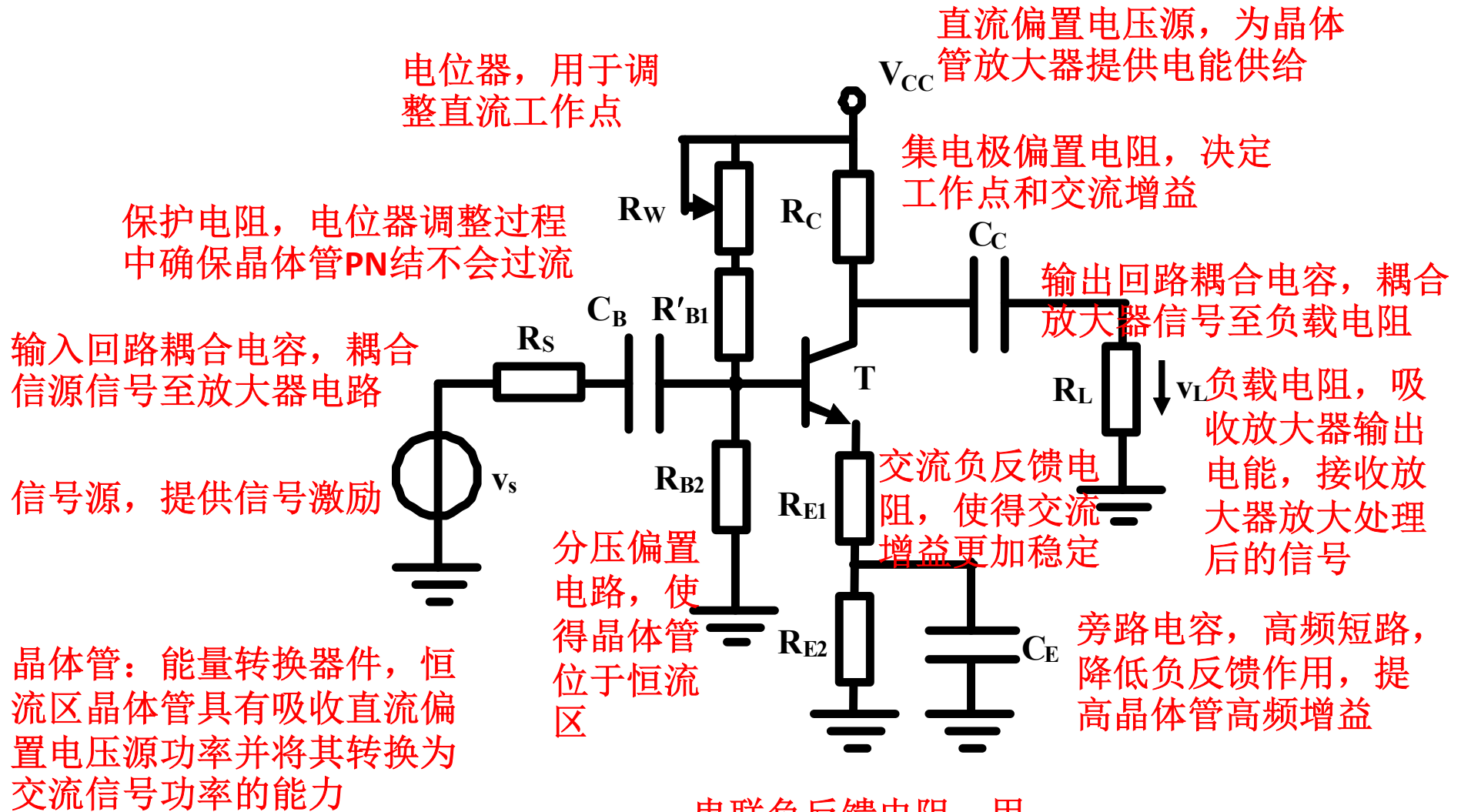

直流工作点的影响

直流负载线

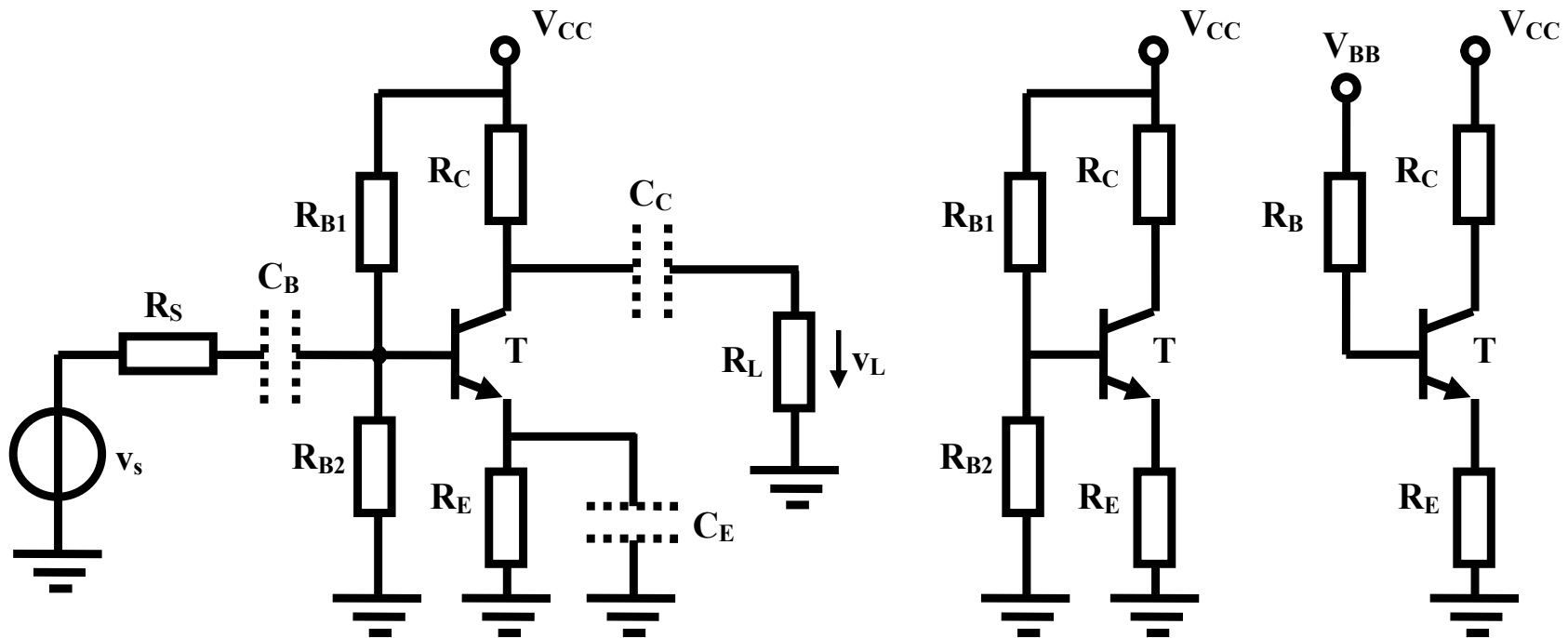

$$V_{CE} = V_{CC} - I_C R_C - I_E R_E \approx V_{CC} - I_C (R_C + R_E)$$

工作点确定

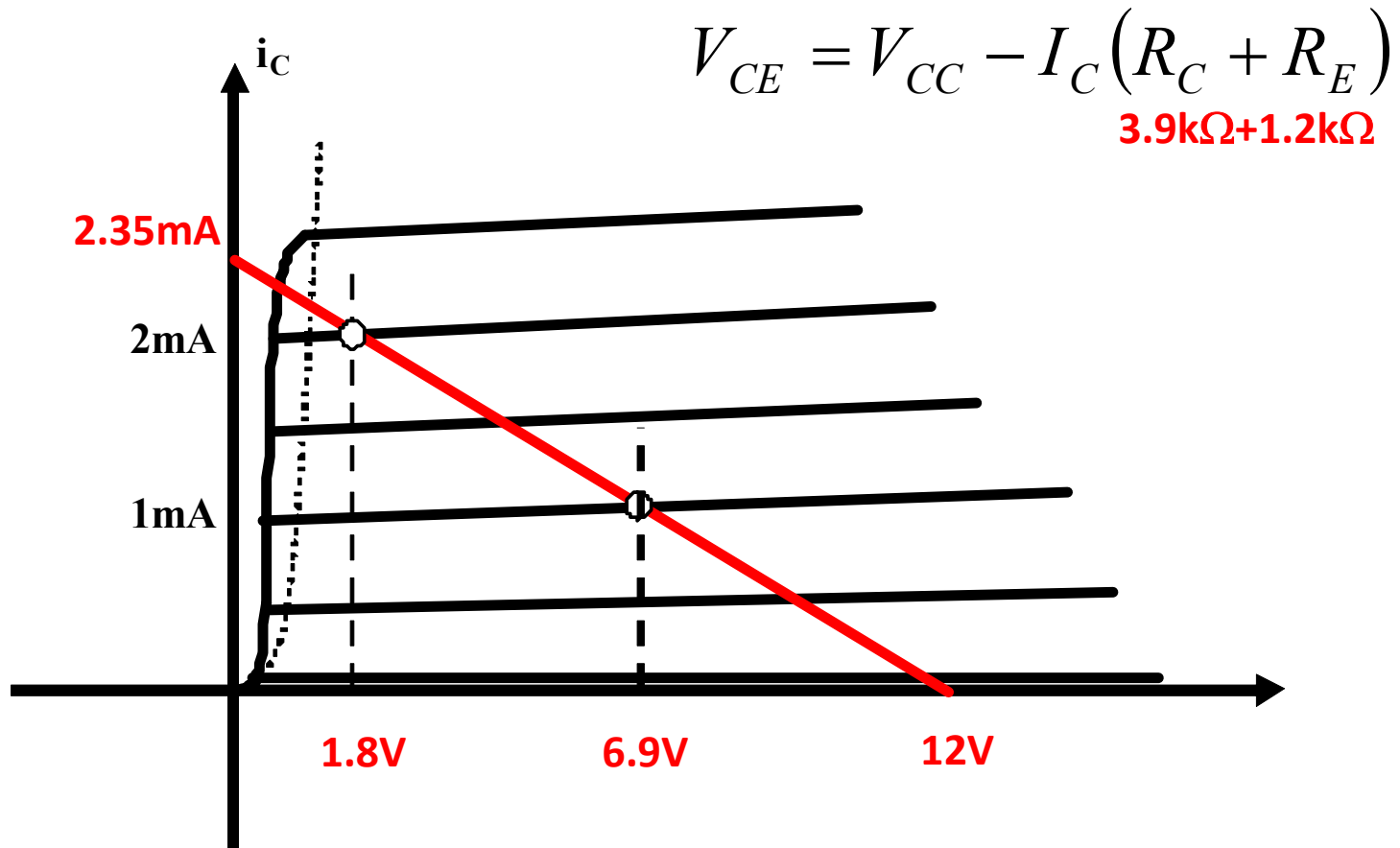

交流负载线

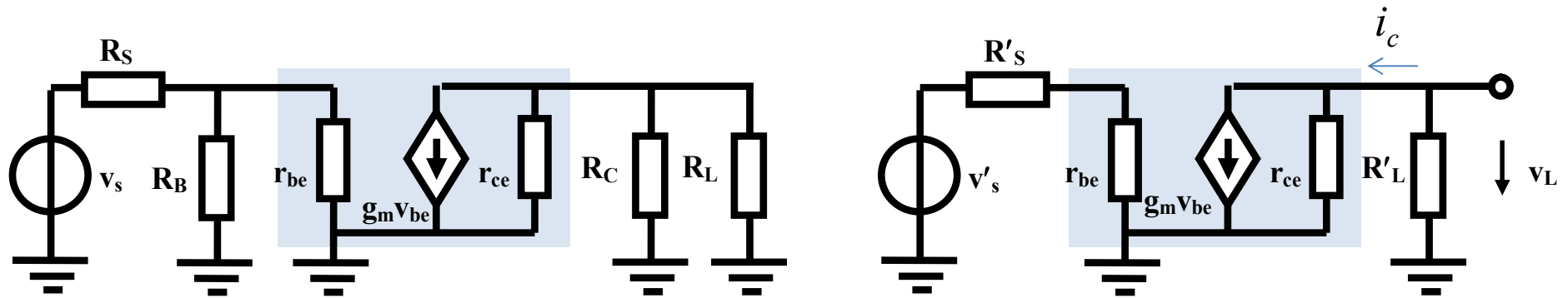

$$v_{ce} = -i_c (R_C \parallel R_L)$$

$$3.9\text{k}\Omega \parallel 5.1\text{k}\Omega = 2.2\text{k}\Omega$$

交流负载线与大信号失真

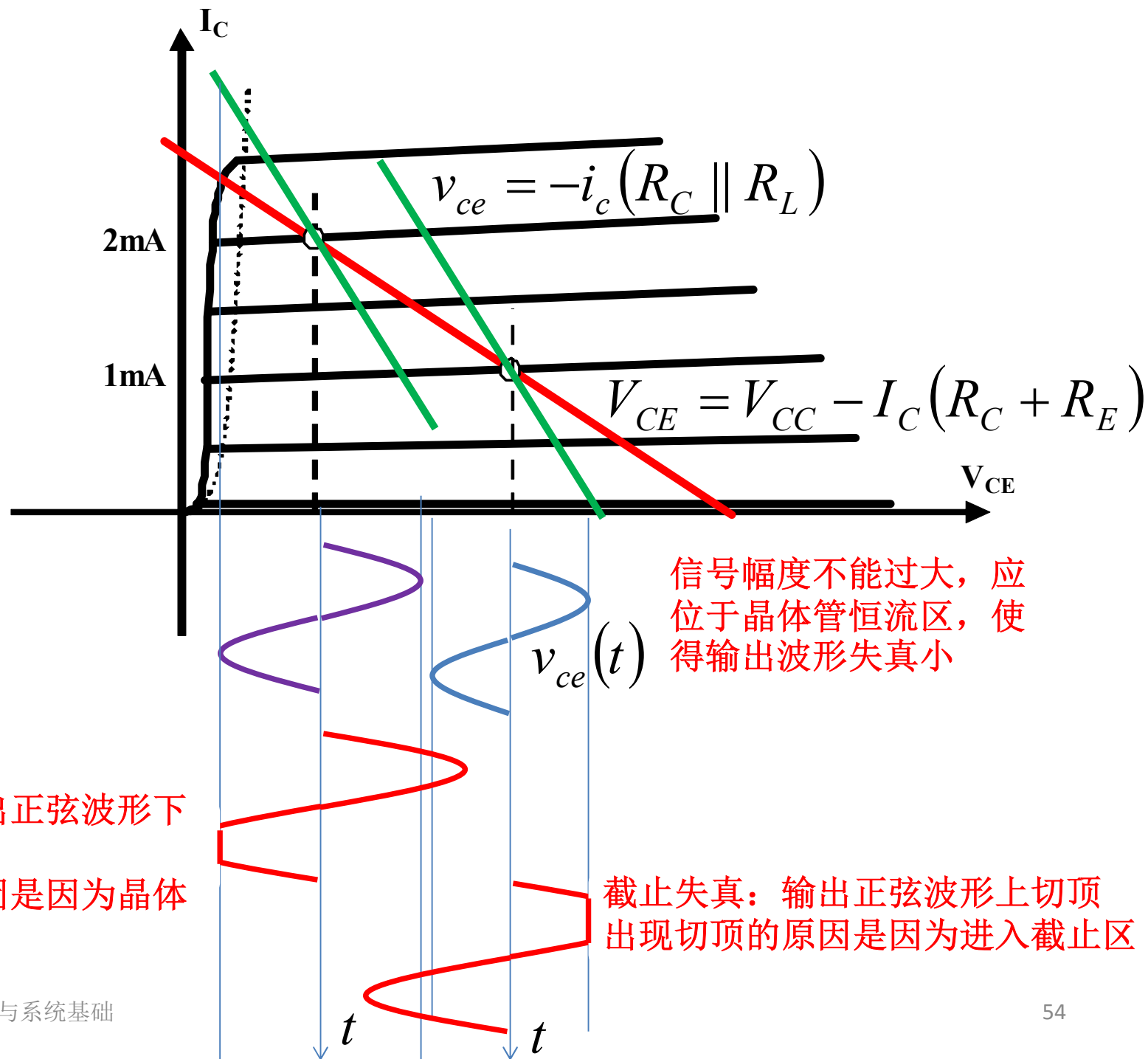

信号幅度不能过大，应位于晶体管恒流区，使得输出波形失真小

饱和失真：输出正弦波形下切顶
出现切顶的原因是因为晶体管进入饱和区

截止失真：输出正弦波形上切顶
出现切顶的原因是因为进入截止区

失真描述

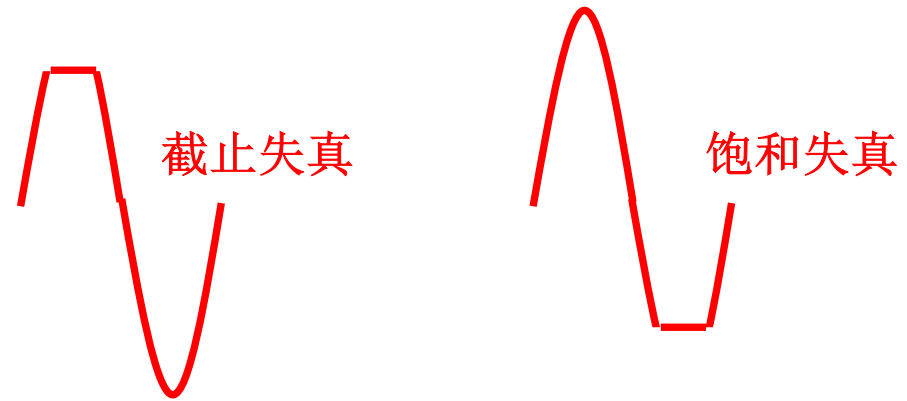

$$v_{in}(t) = V_{im} \cos \omega_0 t$$

周期激励

$$v_{out}(t) = V_{o0} + V_{om} \cos \omega_0 t + V_{o2} \cos 2\omega_0 t + V_{o3} \cos 3\omega_0 t + \dots$$

周期响应

正负半周不对称，有直流偏移量

基波分量

高次谐波分量

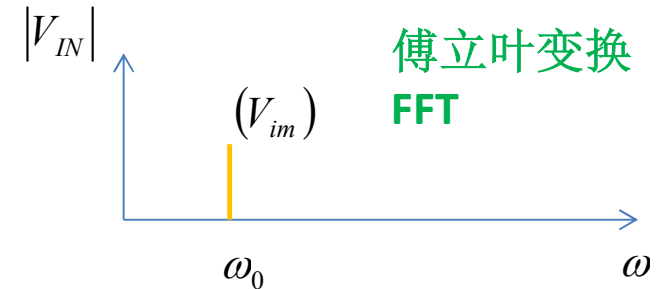

傅立叶变换
FFT

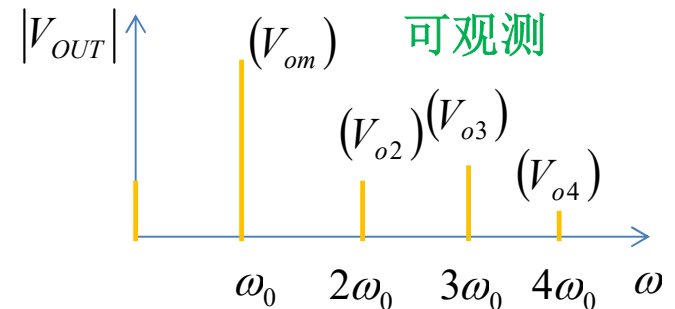

示波器FFT功能
可观测

$$THD = 10 \log \frac{V_{o2}^2 + V_{o3}^2 + V_{o4}^2 + \dots}{V_{om}^2}$$

总谐波失真

$$HD_2 = 10 \log \frac{V_{o2}^2}{V_{om}^2}$$

二次谐波失真

$$HD_3 = 10 \log \frac{V_{o3}^2}{V_{om}^2}$$

三次谐波失真

如果示波器FFT显示采用dB数，基波与高次谐波dB数之差就是该次谐波失真大小

线性度描述：可人为给出某种定义

- **1dB线性范围**
 - 在该范围内，微分增益变化不超过**1dB**
 - 有转移特性曲线表达式，易于理论分析
- **30dB总谐波失真线性范围**
 - 正弦波幅度在该范围内变化，总谐波失真小于**30dB** $THD \leq -30dB$
 - 方便示波器、频谱分析仪等实际观测

动态范围

$$v_{in}(t) = V_{im} \cos \omega t$$

非线性失真导致

$$v_{out}(t) = V_{om} \cos \omega t + \text{高次谐波分量}$$

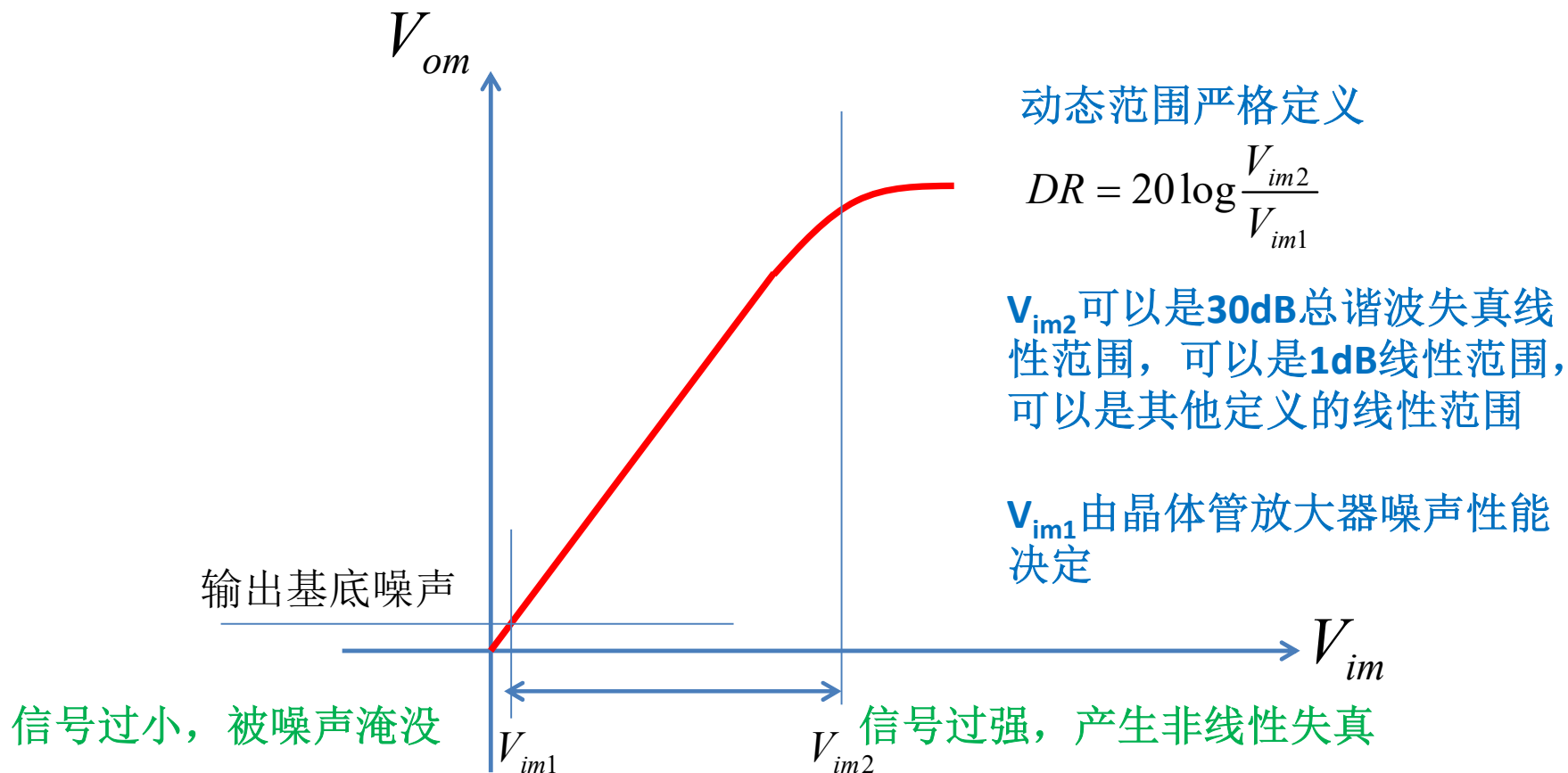

动态范围：信号幅度在该范围内，可认为是接近理想的线性系统

实验教材中的动态范围定义

- 定义高次谐波失真小于**30dB**的信号幅度为线性范围

- V_{im1} 不好测量，这里不测

- V_{im2} 定义为 $HD_2 < -30dB$ $HD_3 < -30dB$

- $HD_4 < -30dB$

- 称 $V_{im2}-V_{im1} \approx V_{im2}$ 为动态范围

- 方便称呼，非动态范围的严格定义

- 动态范围严格定义

$$DR = 20 \log \frac{V_{im2}}{V_{im1}}$$

线性范围最大的最佳工作点

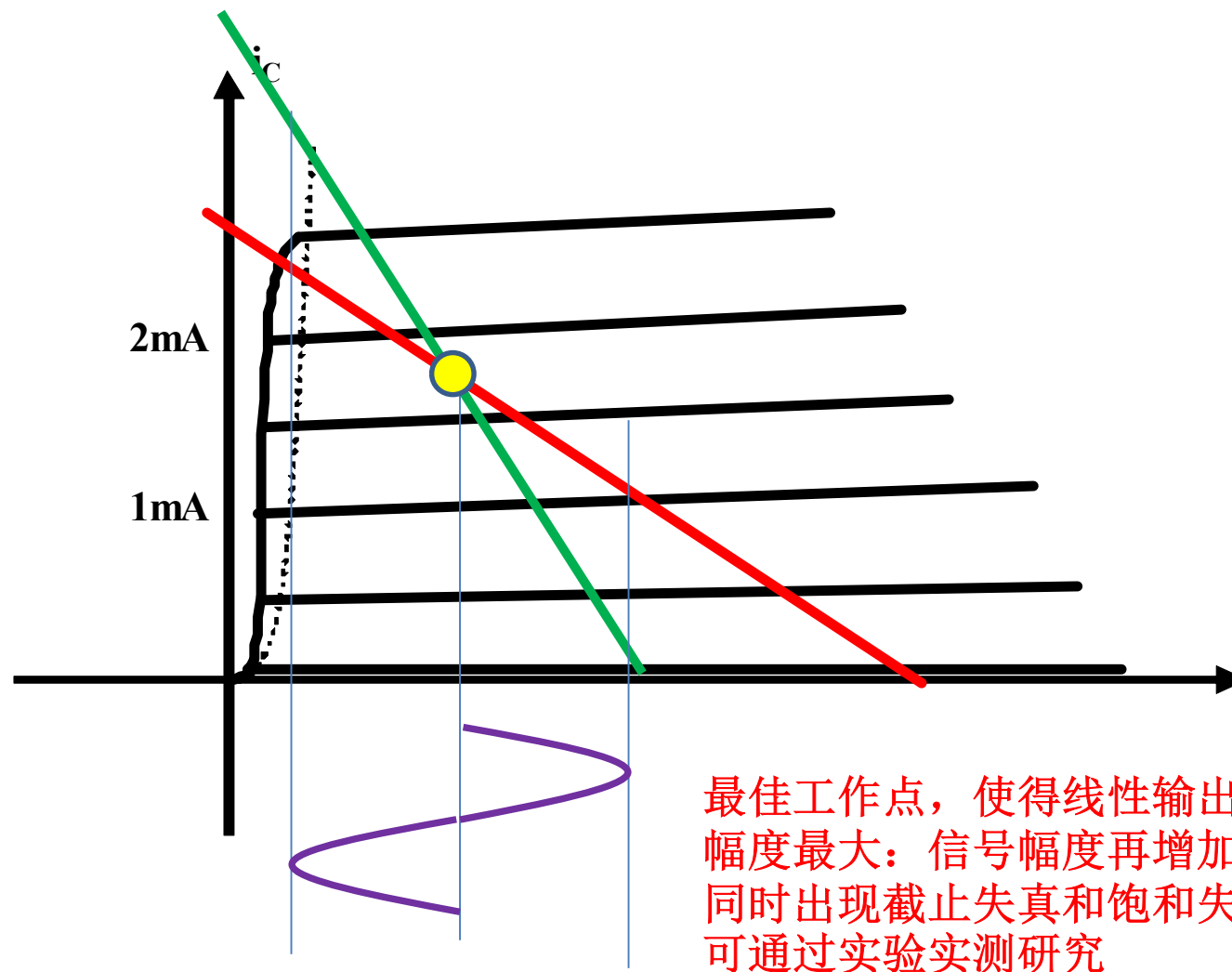

带宽形成的定性分析

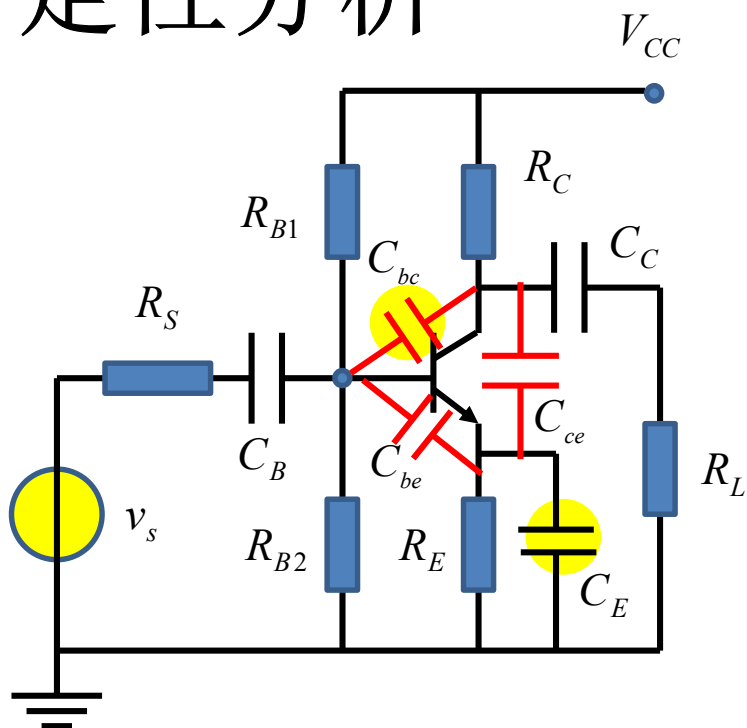

位于中间频段时

C_B 、 C_C 、 C_E 大电容，高频短路

C_{be} 、 C_{ce} 、 C_{bc} 小电容，低频开路

电路中不考虑电容效应，就是理论课CE组态放大器电路分析结果

频率很低时

C_B 开路，信号无法通过

C_C 开路，信号无法通过

C_E 开路，信号增益很小

$$v_s(t) = V_{im} \cos(\omega t)$$

$$v_L(t) = V_{om} \cos(\omega t + \varphi)$$

$$|A_0| = \frac{V_{om}}{V_{im}}$$

频率极高时

C_{be} 短路，输入端信号接地，信号被短接于地

C_{ce} 短路，输出端信号接地，信号被端接于地

C_{bc} 短路，跨导器作用消失，不具放大作用

